

Panasonic®

Operating Instructions

Commercial Microwave Oven

Model No. **NE-1866 / NE-1566**

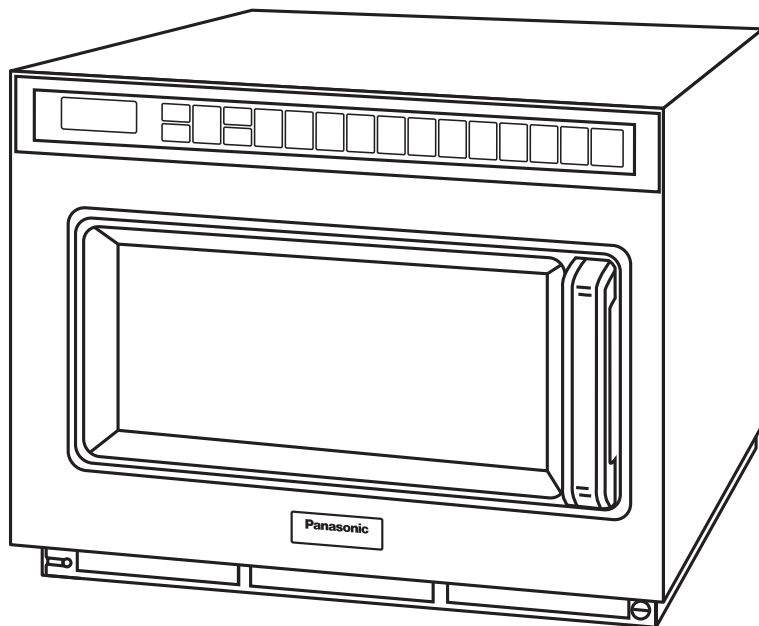

Thank you for purchasing this Panasonic product.

CAUTION: Please read these instructions completely before operating this oven and keep for future reference. Before using this product, **please pay extra attention to "Important Safety Instructions" (pages 3-5).**



F00033J90QP

Contents

	Page
Important Safety Instructions	3
Care of Your Microwave Oven	6
Installation Instructions for Stacking	7
Types of Container to Use	8
Before Use	9
Definitions and Feature Explanations	10
Outline Diagram	11
How to Operate	12
A. Manual Single Stage Heating	12
B. Manual 2 to 5 Stage Heating	13
C. Programming Memory Pads for Single Stage Heating	14
D. Programming Memory Pads for 2 to 5 Stage Heating	15
E. Memory Pad Heating	15
F. Programming Double/Triple Quantity Pad	16
G. Memory Pad Heating for Double/Triple Quantity Heating	17
H. +10s/+20s Pad Heating	17
I. To Read the Cycle Counter	18
J. To Activate Program Lock	18
K. To Deactivate Program Lock	18
L. To Read Program List	19
M. To Select Beep Tone Options	20
N. Procedure to Program the Air Filter Cleaning Cycle	21
O. Oven Lamp	22
Before Cooking	24
Cooking Instructions – Heating and Defrosting Time Charts –	25
Self Diagnostics Failure Code Explanation	26
Specifications	27

Panasonic Australia Pty Ltd
 1 Innovation Road
 Macquarie Park
 NSW 2113



Panasonic NZ Ltd
 18 Sir Woolf Fisher Drive
 Highbrook, Auckland
 Private Bag 14911
 Panmure, Auckland

This product is an equipment that fulfills the European standard for EMC disturbances (EMC = Electromagnetic Compatibility) EN 55011. According to this standard this product is an equipment of group 2, class B and is within required limits. Group 2 means that radio-frequency energy is intentionally generated in the form of electromagnetic radiation for warming and cooking of food. Class B means that this product may be used in normal household areas.

Important Safety Instructions

INSTALLATION

EXAMINE YOUR OVEN

Unpack the oven, remove all packing material, and examine the oven for any damage such as dents, broken door latches or cracks in the door. Notify the dealer immediately if the unit is damaged. **DO NOT** install it if the unit is damaged.

EARTHING INSTRUCTIONS

This microwave oven must be earthed. In the event of an electrical short circuit, earthing reduces the risk of electric shock by providing an escape wire for the electric current.

This microwave oven is equipped with a cord having an earthing wire with an earthing plug. The plug must be plugged into an outlet that is properly installed and earthed.

WARNING—Improper use of the earthing plug can result in a risk of electric shock.

WARNING—15 A (NE-1866) or 10 A (NE-1566) OUTLET TO BE USED ONLY. **DO NOT REMOVE APPROVED 15 AMP (NE-1866), 10 AMP (NE-1566) PLUG.**

VOLTAGE AND POWER WARNING

The voltage used must be the same as specified on the microwave oven. Using another voltage than that which is specified is dangerous, and may result in a fire or other type of accident causing damage. Do not plug your oven in via an extension cable as this can be dangerous. It is important to plug the oven directly into a wall socket.

The back of the appliance heats up during use. Do not allow the cord to be in contact with the back of the appliance or cabinet surface.

PLACEMENT OF THE OVEN

Locate the oven on a surface which is flat and stable. Do not place the oven in a hot or damp place; e.g. near a gas or electric range. Do not operate the oven when the room temperature is higher than 40°C and/or the humidity is more than 85%. Free airflow around the oven is important.

There is a possibility of a small amount of interference with weak broadcast signals if the microwave oven is too close to a radio or TV.

For safe and efficient operation, the oven must have sufficient air flow to the air vents i.e. 5 cm at both sides and rear, and 20 cm at the top.

This microwave oven requires free airflow in the back for maximum cooling efficiency. You should keep the air vents clear while cooking.

Do not install appliances at higher than 1.6 m and also, less than 0.85 m.

Oven must be placed for easy access to control panel and door and also, for disconnect power or shut off power by fuse or circuit breaker.

This appliance is also intended to be used in an area open to the public.



An external equipotential bonding conductor is provided at the back side of the oven and it is marked by this symbol.

WARNING

1. To reduce the risk of burns, electric shock, fire, injury to persons or excessive microwave energy: Read all instructions before using microwave oven.
2. If the door or door seals are damaged, the oven must not be operated until it has been repaired by a qualified service personnel.
3. The contents of feeding bottles and baby food jars shall be stirred or shaken and the temperature checked before consumption, in order to avoid burns.
4. Liquids and other foods must not be heated in sealed containers since they are liable to explode.
5. Microwave heating of beverages can result in delayed eruptive boiling, therefore care must be taken when handling the container.
6. It is hazardous for anyone other than a competent person to carry out any service or repair operation that involves the removal of a cover which gives protection against exposure to microwave energy.

Important Safety Instructions

CAUTION

1. In order to maintain the high quality of the components, you are requested not to turn the oven on with no food inside.
2. High voltages are present inside the cabinet. Repairs and adjustments should be done only by qualified service personnel.
3. Do not dry clothes in the microwave oven since there is a possibility of the clothes burning if left in the oven for too long of a time.
4. Use this microwave oven only for its intended use as described in this manual.
5. Do not operate this microwave oven, if it is not working properly, or if it has been damaged or dropped.
6. Do not use this microwave oven outdoors.
7. Do not immerse cord or plug in water.
8. Keep cord away from heated surfaces.
9. Do not let cord hang over edge of table or counter.
10. To reduce the risk of fire in the oven cavity:
 - a) Do not overcook food. When heating food in plastic or paper containers, keep an eye on the oven due to the possibility of ignition.
 - b) Remove wire twist-ties from bags before placing bag in oven.
 - c) If materials inside the oven should ignite, keep oven door closed, unplug the oven, or shut off power at the fuse or circuit breaker panel.
11. The appliance should not be operated without food in the oven, operation in this manner being likely to damage the appliance.
12. Do not store flammable materials next to, on top of, or in the oven.
It could be a fire hazard.
13. DO NOT use this oven to heat chemicals or other non-food products. DO NOT clean this oven with any product that is labelled as containing corrosive chemicals. The heating of corrosive chemicals in this oven may cause microwave radiation leaks.
14. Do not use your oven for home canning or the heating of any closed jar. Pressure will build up and the jar may explode. In addition, the microwave oven cannot maintain the food at the correct canning temperature. Improperly canned food may spoil and be dangerous to consume.
15. Do not attempt to deep fat fry in your microwave oven.
16. Potatoes, apples, egg yolks, whole squash and sausages are examples of foods with nonporous skins. This type of food must be pierced before cooking, to prevent bursting.
17. DO NOT USE A CONVENTIONAL MEAT THERMOMETER IN THE MICROWAVE OVEN. To check the degree of cooking of roasts and poultry, use a MICROWAVE THERMOMETER. Alternatively, a conventional meat thermometer may be used after the food is removed from the oven. If undercooked, return meat or poultry to the oven and cook for a few more minutes at the recommended power level. It is important to ensure that meat and poultry are thoroughly cooked.
18. Extreme care should be taken when cooking popcorn in a microwave oven. Cook for minimum time as recommended by manufacturer. Use the directions suitable for the wattage of your microwave oven. NEVER leave oven unattended when popping popcorn.
19. When reheating baby bottles always remove the top and teat. Liquid at the top of the bottle will be much hotter than at the bottom and must be shaken thoroughly before checking the temperature.
20. The door seals and door seal areas should be cleaned with a damp cloth.
21. If smoke is observed, unplug the oven, or shut off power at the fuse or circuit breaker, and keep the door closed in order to stifle any flames.
22. If the supply cord is damaged, it must be replaced by the manufacturer, its service agent or similarly qualified person in order to avoid a hazard.
23. Before use, the user should check that utensils are suitable for use in the microwave oven.
24. When heating liquids, e.g. soup, sauces and beverages in your microwave oven, overheating the liquid beyond boiling point can occur without evidence of bubbling. This could result in a sudden boil over of the hot liquid. To prevent this possibility the following steps should be taken:
 - a) Avoid using straight-sided containers with narrow necks.
 - b) Do not overheat.
 - c) Stir the liquid before placing the container in the oven and again halfway through cooking time.
 - d) After heating, allow to stand in the oven for a short time, stirring again before carefully removing the container.
25. Eggs in their shells and whole hard-boiled eggs should not be heated in the microwave oven since they may explode, even after microwave heating has ended.

Important Safety Instructions

26. This appliance can be used by children aged from 8 years and above and persons with reduced physical, sensory or mental capabilities or lack of experience and knowledge if they have been given supervision or instruction concerning use of the appliance in a safe way and understand the hazards involved. Children shall not play with the appliance. Cleaning and user maintenance shall not be made by children without supervision.
27. The appliance should not be cleaned with a water jet.
28. The appliance should not be cleaned with a steam cleaner.
29. Electromagnetic fields can present a possible danger. We would recommend that people using a heart pacemaker avoid proximity to these fields.
30. When the oven is not in use, it is recommended that items are removed. If left inside and the switch is accidentally activated, there is potential for damage to occur.
31. Do not use recycled paper products, as they may contain impurities which may cause sparks and/or fires when used, unless packaging states they are specifically designed for microwave use.
32. During service and/or replacement of parts, the oven should be disconnected from the power supply. Once the plug is removed, it should remain visible to the service operator to avoid inadvertent reconnection.
33. Failure to maintain the oven in a clean condition could lead to deterioration of the surface that could adversely affect the life of the appliance and possibly result in a hazardous situation.
34. The oven should be cleaned regularly and any food deposits removed.
35. Do not use metalware, ceramics trimmed with gold or silver, or any container with a metal content.

USING YOUR OVEN

Do not store any objects inside the oven in case it is accidentally turned on.

In case of electronic failure, unplug the oven.

MAINTENANCE OF YOUR OVEN

If your oven should require a service, call the dealer or service agent.

Do not attempt to make any adjustments or repairs to any part of the oven.

Care of Your Microwave Oven

Failure to maintain the oven in a clean condition could lead to deterioration of the surface that could adversely affect the life of the appliance and possibly result in a hazardous situation.

1. Remove the plug from the electrical socket before cleaning.
2. Keep the inside of the oven clean. If pieces of food or spilled liquids stick to the oven walls, or between door seal and door surface, they will absorb microwaves and may cause arcing or sparks. Wipe up all spills with a damp cloth. Kitchen detergent or Food Sanitizer Solution may be used if the oven gets very dirty. Do not use harsh detergents or abrasives.
3. The outside surface and the outer door of this microwave oven should be cleaned with soap and water, then dried with a soft cloth. Make sure that water does not get into the back ventilation or control panel opening since this can damage the unit.
4. The window of the door should be washed with very mild soap and water. Be sure to use a soft cloth. Never use window cleaner. The front door can be scratched by harsh soap or cleaners.

CLEANING OF THE SPLATTER SHIELD

1. Hold snap in / snap out stoppers of splatter shield with both hands and pull them in and down. Then take the splatter shield out of the oven cavity.
2. Rinse splatter shield in soapy water or Food Sanitizer Solution and dry it completely.
3. Be sure to replace the shield before using the oven.

CAUTION

Splatter shield must be in place securely when you use the oven.

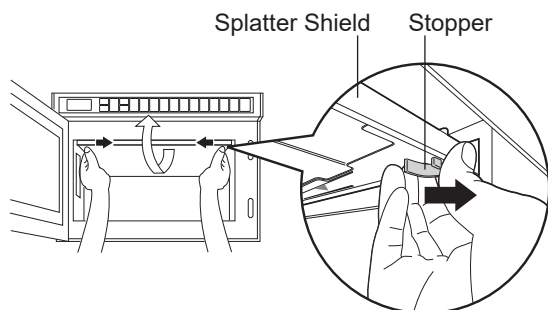

"rFL" is displayed if the splatter shield is removed. (See page 26.)
Place the splatter shield securely after cleaning.
The oven is inoperative without it.

CLEANING OF THE AIR FILTER

Clean the Air Filter regularly according to the following instructions. If the Air Filter becomes clogged with debris, this will cause an overheating problem with the oven.

1. Remove the Air Filter from the front bottom skirt by turning the right screw to the left. Then slide the filter to the right and lift it off the post at the left.
2. Wash this filter in warm soapy water and dry it completely.
3. Be sure to replace the Air Filter before using the oven.

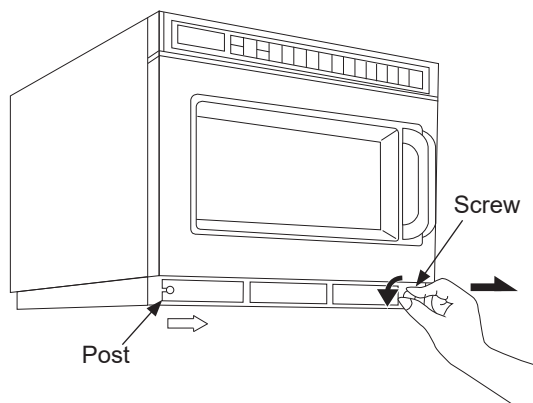

Installation Instructions for Stacking

Important

1. Disconnect the power cord from the wall socket before attempting installation.
2. For stacking installation, you must use the Panasonic Joint Plate F1134-3E10 (Available via service route).
3. Combination of the unit for stacking is limited within the following models.
NE-1878, NE-1866, NE-1566
4. Do not stack more than one oven above bottom oven.

Preparation

Be sure the oven cavity is empty.

Installation

1. Stack the units and remove five screws (a) as shown in Fig. 1.
2. Loosen the screw (b).
3. The projection on the Joint Plate must face away from the oven. Place the Joint Plate on the screw (b).
4. Attach and tighten five screws (a) and the screw (b). See Fig. 2.
5. Ensure the top oven is at a safe and workable height.

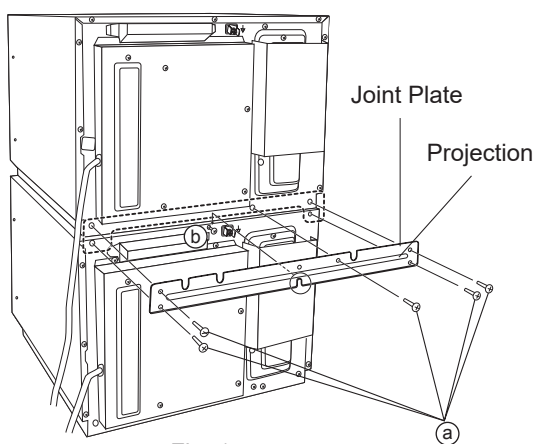

Fig. 1

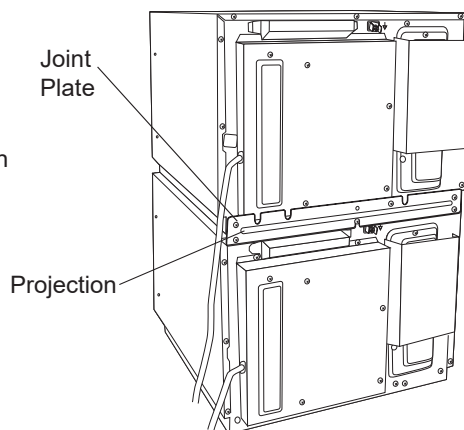

Fig. 2

Types of Container to Use

1. GLASS

DO USE: Heat resistant glass e.g. Pyrex®
DO NOT USE: Delicate glass, lead crystal, etc, which may crack or arc.

2. CHINA/CERAMICS

DO USE: Glazed china dishes, porcelain and ceramic dishes designed for cooking.
DO NOT USE: Fine bone china dishes with metal patterns. Jugs with glued handles.

3. POTTERY/EARTHENWARE/STONEWARE

DO USE: If completely glazed.
DO NOT USE: If unglazed - these dishes can absorb water which absorbs energy.
This makes the dish hot and increases the heating time.

4. FOIL/METAL

DO NOT USE: Metal platters, Wire Rack Shelf, METAL SKEWERS, any dish with METAL PATTERN or TRIM.
DO NOT USE FOIL CONTAINERS - ARCING may occur as they become DENTED / DAMAGED. Do not use Le Crueset-style dishes (Cast iron covered by enamel).

5. PLASTIC

DO USE: High temperature plastic like Durable Polysulfon rather than soft flexible dishes.
(Remove any metal twist ties.)
DO NOT USE: Container made from Melamine, Polypropylene, Phenol Urea, also do not use plastic food storage bags and containers e.g. Margarine, Yoghurt and Mayonnaise tubs.

6. COVERING FILMS

DO USE: Non plasticiser cling film designed for microwave use. Do not allow the film to touch the food. To prevent nasty steam burns, pierce the film to allow steam to escape and remove the film from the dish carefully.
DO NOT USE: Film designed only for covering food.

7. WOOD/WICKER

DO USE: Wooden skewers designed for food use.
DO NOT USE: Wicker baskets, wooden bowls (with prolonged use these tend to dry out and may ignite)

8. PAPER

DO USE: Disposable, polyester coated paper board dishes if designed for microwave.
DO NOT USE: Paper napkins (these can ignite), wax coated cups, recycled products (unless stated suitable by manufacturer)

Before Use

Cookware

1. Heat-proof glassware, such as Pyroceram and Pyrex®, is best suited for use in the Microwave Oven.
2. If “arcing” should occur, check the cookware carefully again for metal.
3. You may use ordinary glassware, chinaware, plastic-ware and paper-ware, when cooking food that requires a low temperature. Using this type of cookware for high temperature cooking may cause cracking or warping.
4. You can cook steamed vegetables in special “see-through” wrapping film, such as cling film, or wax paper. Do not cook in a plastic bag.
5. Before using the oven always check that containers are suitable. DO NOT MICROWAVE sealed containers as they may explode.
6. DO NOT leave the appliance unattended if paper, plastic or other combustible containers are used. Do not use recycled paper products, as they may contain impurities which may cause sparks and/or fires when used, unless packaging states they are specifically designed for MICROWAVE use.

CAUTION

Do not use METAL UTENSILS in this oven.

Defrosting Frozen Food

1. If you try to completely defrost frozen food in the Microwave Oven, uneven defrosting may occur due to the differences in the thickness and shape of the food. Drip may also result, and sometimes a part of the food cooks although other parts still remain frozen. In actual usage of frozen foods, you should not normally defrost them 100%, 70% defrosting in the Microwave Oven is ideal and helpful for the next cooking operation.
2. To defrost evenly, turn over or rearrange the food during defrosting.
3. To defrost fatty meat, heat it in the Microwave Oven for a short time and leave it to stand at room temperature, or heat it intermittently until defrosted.
4. Ice should be removed at times during defrosting.

Other Helpful Instructions

For best results

1. As microwave cooking times are much shorter than other cooking methods it is essential that recommended cooking times are not exceeded without first checking the food. Factors that may affect cooking times are: preferred degree of cooking, starting temperature, altitude, volume, size and shape of foods and utensils used. As you become familiar with the oven, you will be able to adjust these factors. It is better to undercook rather than overcook foods. If food is undercooked, it can always be returned to the oven for further cooking. If food is overcooked, nothing can be done. Always start with minimum cooking times.

IMPORTANT

If the recommended cooking times are exceeded, the food will be spoiled and in extreme circumstances it could catch fire and possibly damage the interior of the oven.

2. Be careful of the cooking time for small quantities of foods, or foods with low water content. They may burn if cooked too long.
3. Do not use the oven for drying kitchen towels or napkins. They may burn if heated too long.
4. Do not try to boil eggs in the oven.
5. When you cook an egg be sure to pierce the yolk membrane prior to placing into the oven to prevent the egg from bursting.
6. To achieve more even cooking result, give the dish a half-turn, or turn the food over.
7. Christmas puddings and other foods high in fats or sugar, e.g. jam, mince pies, must not be over heated. These foods must never be left unattended as with over cooking these foods can ignite.
8. It is essential that reheated food is served “piping hot”. Remove the food from the oven and check that it is “piping hot”, i.e. steam is being emitted from all parts and any sauce is bubbling. If you wish you may choose to check the food has reached 72°C with a food thermometer—(but remember do not leave this thermometer inside the microwave.) or to a temperature recommended by Government Food Hygiene Regulations. For foods that cannot be stirred, e.g. lasagne, shepherds pie, the centre should be cut with a knife to test it is well heated through. Even if a manufacturer’s packet instructions have been followed, always check the food is piping hot before serving it. If in doubt return your food to the oven for further heating.
9. Standing time refers to the period at the end of cooking or reheating when food is left before being eaten, i.e. it is a rest time which allows the heat in the food to continue to conduct to the centre, thus eliminating cold spots.

Definitions and Feature Explanations

This oven has many features not typically found on other commercial Microwave Ovens.

FEATURE	EXPLANATION
Single Stage Heating (See pages 12-13.)	Allows the oven to run at the selected power level for the selected heating time.
Manual Heating (See pages 12-14.)	Gives the user maximum flexibility to set the oven to desired heating time and power level. Ideal for menus that require variations in heating.
Repeat Feature For Manual Heating Only (See page 13.)	After you remove your food from the oven, the timer is automatically preset to repeat the last heating time and power level. This is especially convenient for daily specials that you do not want to program into Memory Pads.
2 to 5 Stage Heating (See pages 13-15.)	Allows the oven to be set to begin heating at one power level then shift automatically to a different power level after designated amount of heating time.
Double/Triple Quantity Pad (See pages 16-17.)	This Pad has a preset magnification of 1.6 times the original cooking time for double quantity and 2.2 times for the triple quantity, to cook two or three portions at once.
+10s/+20s Pad (See page 17.)	This Pad has preset heating times of 10 seconds and 20 seconds. The heating at P10 power for 10 seconds will start by touching this Pad once, and the heating at P10 power for 20 seconds will start by touching this Pad twice.
Interrupt Feature (See page 18.)	Allows opening of the oven door to check on the food in the cavity. Closing the door and touching Start Pad resumes heating. Cooking time does not countdown while you check on your food. Note: Interrupt Feature is deactivated in "Program Lock".
Cycle Counter (See page 18.)	The oven can display the total cooking hours of usage, and total number of times that the oven has been operated by manual operation and cumulatively. Great for analysing usage of the oven and traffic flow at the location.
Program Lock (See page 18.)	<ol style="list-style-type: none"> 1. "Locks" the control panel number pads into their programmed heating times and power levels. 2. The oven is started by touching the desired Memory Pad. There is no need to touch Start Pad. 3. Deactivates programming memory pads. 4. Deactivates manual operation. Prevents unwanted erasing of Memory Pads. Simplifies operation—Great for Fast Food, Convenience Store and Vending applications.
Program Unlock (See page 18.)	Deactivates "Program Lock" and activates all other features.
Program List (See page 19.)	Allows you to review all currently programmed Pad numbers, heating times and Power levels for each stage.
Beep Tone Loudness Control (See page 20.)	Allows you to set the loudness of the beep tone to one of 4 different levels.
Beep Tone Length Control (See page 20.)	Allows you to set the length of the end of heating cycle beep tone to one of 3 different lengths.
Beep Tone Pitch Control (See page 21.)	Allows you to set the pitch of the end of heating cycle beep tone to one of 3 different pitches.
Filter Clean Function (See pages 21-22.)	The word "FILt" will appear in the display after 500 hours of use, to remind you to remove and clean the Air Filter. This time can be reprogrammed to your own needs.
Oven Lamp Control (See page 22-23.)	Allows you to set the oven lamp on/off when the door is opened, the oven lamp blinking on/off when heating is finished, and the oven lamp brightness during cooking.
Self Diagnostics (See page 26.)	The oven constantly monitors its operation. When an operational problem develops, the Digital Display Window displays a Failure code. By checking the code number against the list in this manual you will know the nature of the problem, whether you can solve the problem yourself, or need to call a service agent or need to call an electrician. If a service agent is required the Failure code number will let him know which parts to bring on the Service call.

Outline Diagram

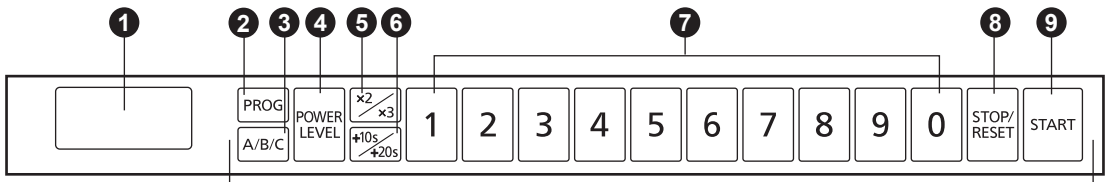

This illustration is for reference only.

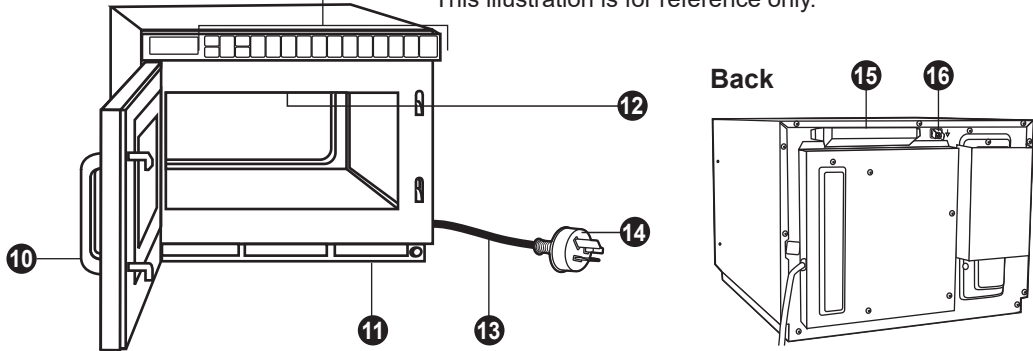

Caution label is attached on the outside surface.

- ① Digital Display Window (see below)
- ② Prog (Program) Pad
- ③ Shift (A/B/C) Pad
- ④ Power Level Selector Pad
- ⑤ Double/Triple Quantity Pad
- ⑥ +10s/+20s Pad
- ⑦ •Number/Memory Pads
 - Time Input
- ⑧ Stop/Reset Pad

- ⑨ Start Pad
- ⑩ Door Handle
- ⑪ Air Filter
- ⑫ Splatter Shield (top of inner cavity)
- ⑬ Power Cord
- ⑭ Power Plug
- ⑮ Exhaust Vent
- ⑯ External equipotential bonding conductor

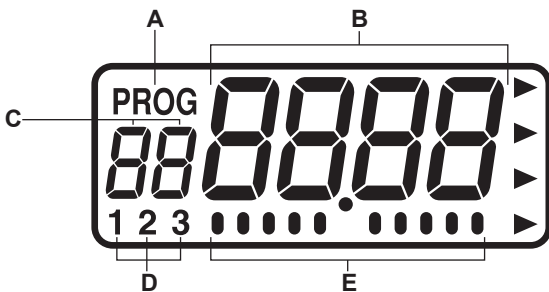

- A—Program Display
- B—Heating Time Display
("min. sec." or "hour. min.")
- C—•Memory Pad Number Display
 - Heating Stage Indicator
- D—Pattern of Beep Sound Setting
- E—•Calling Programmed Heating:
 - Stage Number Indicator
 - Programmed Heating in Progress: Operation Indicator
 - Beep Tone Setting: Scale Indicator

This oven is preset at the factory for the following:

1. Manual operation
2. Number Pads preset to P10 power at the indicated heating times for single stage heating.

A1=10 sec.	A2=20 sec.	A3=30 sec.	A4=40 sec.	A5=50 sec.
A6=1 min.	A7=1 min. 15 sec.	A8=1 min. 30 sec.	A9=1 min. 45 sec.	A0=2 min.
3. Program unlock
4. Double Quantity=1.6 times Triple Quantity=2.2 times
5. Oven Lamp When the door is open = ON Blinking at the end of heating cycle = OFF
Decrease brightness during cooking = OFF
6. The default filter cleaning time is set to "0" for the first stage and "500" for the second stage.

If you wish to change these times, consult the operating instructions to find how to program them.

How to Operate

POWER LEVEL SELECTOR PAD

Each time the pad is touched, the Power Level switches as the illustration below.

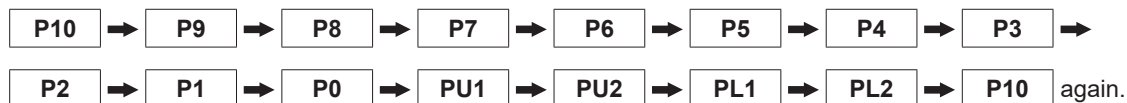

HIGH	P10: 1800 W* (NE-1866) 1500 W* (NE-1566)	LOW	P3: 30% P2: 25%
MEDIUM HIGH	P9: 90% P8: 80% P7: 70% P6: 60%	DEFROST	P1: 340 W
		OFF	P0: 0%
MEDIUM	P5: 50% P4: 40%	HEAT FROM TOP DOWN	PU1: 50% PU2: 25%
		HEAT FROM BOTTOM UP	PL1: 50% PL2: 25%

*IEC Test Procedure

Before operating the oven, make sure it is plugged into a properly earthed electrical outlet.

A. Manual Single Stage Heating

The oven can not be run manually until the program lock feature is deactivated.

(See page 18, K. To Deactivate Program Lock.)

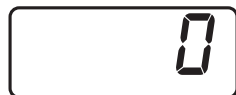

- Open the door.
The oven lamp will turn on. "0" will appear in the Digital Display Window.
- Put the food into a suitable container, place it in the centre of the oven and then close the door securely.
The oven lamp will turn off.
Note: While "0" appears, operation is available. 1 minute after the door is closed, "0" will disappear.



- Select the desired Power Level by touching Power Level Selector Pad.
The selected Power Level will be displayed in the Digital Display Window and the single stage heating indicator "1" will start to blink.
[Example]: Touch Power Level Selector Pad once for P10 power.
Note: Each time Power Level Selector Pad is touched, the Power Level switches as the above Power Level Selector illustrates.



- Set the desired heating time by touching the appropriate Number Pads.
Note: The maximum set time for P1 and P0 is 30 minutes, and 15 minutes for all others.
[Example]: Touch Number Pads "2", "0" and "0" for 2 minutes.



- Touch Start Pad.
 - The oven lamp will turn on.
 - Heating will start.
 - During operation, the indicator appears from the left.
 - The heating time on digital display will count down.
When touching Power Level Selector Pad, the current power level will be displayed for 3 seconds.



- When all time expires, the end of cycle beep tone will sound and all heating will stop. The oven lamp will turn off. The display will blink "0000" until the door is opened. 1 minute later cooling fan will stop.

(Continued on next page.)

How to Operate



7. Open the door and take the food out.
The oven lamp will turn on. The digital display will show the originally selected time and heating stage number.

REPEAT FEATURE

- a. You can repeat exactly the same manually selected heating time by touching only Start Pad, if you use the oven again within 1 minute.
- b. After 1 minute of non-use with the door closed, the repeat feature will be cancelled.



8. Close the door.
The oven lamp will turn off and 1 minute later the Digital Display Window will go blank.

SPECIAL NOTE: For both single and 2 to 5 stage heating.

1. While heating, one touch on Stop/Reset Pad stops the oven. You can restart it by touching Start Pad or a second touch on Stop/Reset Pad will cancel the selected program.
2. While not in a heating cycle, one touch on Stop/Reset Pad cancels the selected program.

B. Manual 2 to 5 Stage Heating



1. Follow Steps 1-4 in "A. Manual Single Stage Heating" on page 12.
2. Select the desired Power Level for the second stage heating by touching Power Level Selector Pad the appropriate number of times.
The Power Level will be displayed in the Digital Display Window and the second stage indicator "2" will start to blink.
[Example]: Touch Power Level Selector Pad 8 times for P3 power.



3. Set the desired heating time for the second stage by touching the appropriate Number Pads.
Note: The maximum set time for P1 and P0 is 30 minutes, and 15 minutes for all others.
However, the TOTAL TIME can be set up to 25 minutes for continuous heating (1 to 5 stage heating) that excludes P1 and P0.
[Example]: Touch Number Pads "1", "0" and "0" for 1 minute.



4. Touch Start Pad.
 - A. The total time for both stages will be displayed.
 - B. The oven lamp will turn on.
 - C. During operation, the indicator appears in order from the left.
 - D. The heating time for the first stage will count down.



5. After the first stage heating time expires, a single beep tone will sound, the second stage heating indicator "2" will start to blink, and the heating time will continue to count down.



6. When all time expires, the end of cycle beep tone will sound. All heating will stop. The oven lamp will turn off. The time display will blink "0000" until the door is opened. 1 minute later cooling fan will stop.

(Continued on next page.)

How to Operate



7. Open the door and take the food out.
The oven lamp will turn on. The digital display will show the originally selected time and heating stage number.



8. Close the door.
The oven lamp will turn off and 1 minute later the Digital Display Window will go blank.

Note: For the heating cycle of the third and later stages, select Power Level once again after Step 3 on page 13 and set a heating time.

See Repeat Feature and Special Note of "A. Manual Single Stage Heating" on page 13.

C. Programming Memory Pads for Single Stage Heating

The oven can not be programmed until the program lock feature is deactivated.

(See page 18, K. To Deactivate Program Lock.)



1. Open the door and leave it open.

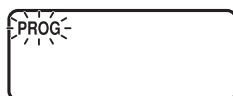

2. Touch Prog Pad.
"PROG" sign will start to blink in the Digital Display Window.



3. Touch Memory Pad you desire to program.
The pad number and the previously programmed information will appear in the Digital Display Window.

[Example]: Touch Memory Pad "5" (Program No. A-5).

Note: When you want to program B or C side, touch Shift (A/B/C) Pad before touching Program Number Pad.



4. Select the desired Power Level by touching Power Level Selector Pad.
The selected power level will be displayed in the window and the single stage heating indicator "1" will start to blink.

[Example]: Touch Power Level Selector Pad 10 times for P1 power.



5. Set the desired heating time by touching the appropriate Number Pad.

Note: The maximum set time for P1 and P0 is 30 minutes, and 15 minutes for all others.

[Example]: Touch Number Pads "1", "0" and "0" for 1 minute.



6. Touch Prog Pad again.
The "PROG" sign and the single stage heating indicator "1" will stop blinking. This means that you have completed programming the selected Memory Pad for the single stage heating.



7. 3 seconds after programming is completed, "0" will appear.
8. Program the remaining Memory Pads as desired by repeating Steps 2-6 above.

Note: When the "PROG" Display is blinking, the program can be cancelled and/or one touch on Stop/Reset Pad erased the programmed Number/Memory Pad number.

How to Operate

D. Programming Memory Pads for 2 to 5 Stage Heating



1. Follow Steps 1-5 in "C. Programming Memory Pads for Single Stage Heating" on page 14.



2. Select Power Level for the second stage by touching Power Level Selector Pad. The selected Power Level will be displayed in the window and the second stage heating indicator "2" will start to blink.
[Example]: Touch Power Level Selector Pad once for P10 power.



3. Set the desired heating time by touching appropriate Number Pads.
Note: The maximum set time for P1 and P0 is 30 minutes, and 15 minutes for all others.
However, the TOTAL TIME can be set up to 25 minutes for continuous heating (1 to 5 stage heating) that excludes P1 and P0.
[Example]: Touch Number Pads "2", "0" and "0" for 2 minutes.



4. Touch Prog Pad again and the "PROG" sign and the second stage heating indicator "2" will stop blinking. The total time for both stages will be displayed. This means that you have completed programming the desired Memory Pad for the second stage heating.



5. 3 seconds after programming is completed, "0" will appear.
6. Program the remaining pads as desired by repeating the Steps above.

Note: To set the heating for the third and later stages, select Power Level again after Step 3 and set the heating time.

E. Memory Pad Heating



1. Open the door.
The oven lamp will turn on. "0" will appear in the Digital Display Window.
Note: While "0" will appear, operation is available. 1 minute after the door is closed, "0" will disappear.

2. Put the food into a suitable container, place it in the centre of the oven and then close the door securely.
The oven lamp will turn off.



3. Touch the desired Memory Pad.
A. The currently programmed information will be indicated.
[Example]: Touch Memory Pad "5" (Program No. A-5).
The total number of stages is displayed as "● ●" in the bottom.
The heating program (at P1 power for 1 minute, at P10 power for 2 minutes) as programmed on pages 14-15 is set.

Note: To use B or C side Program, touch Shift (A/B/C) Pad before touching Program Number Pad.



4. Touch Start Pad.
A. The oven lamp will turn on.
B. During operation, the indicator appears in order from the left.
C. The heating time will count down.
When touching Power Level Selector Pad, the current power level will be displayed for 3 seconds.
D. When touching Start Pad, the current stage number will be displayed for 3 seconds instead of Program No.
Note: If program lock is activated, the heating program starts immediately, i.e. there is no need to touch Start Pad. (See page 18.)

(Continued on next page.)

How to Operate



- When all the time expires, the end of the cycle beep tone will sound. All heating will stop. The oven lamp will turn off. The time display will blink "0000" until the door is opened. 1 minute later, cooling fan will stop.



- Open the door and take the food out.
The oven lamp will turn on.
- Close the door.
The oven lamp will turn off and 1 minute later the Digital Display Window will go blank.

F. Programming Double/Triple Quantity Pad

The oven can not be programmed until the program lock feature is deactivated.
(See page 18, K. To Deactivate Program Lock.)



- Open the door and leave it open.
The oven lamp will turn on, and "0" will appear.

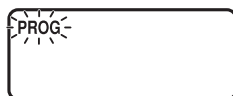

- Touch Prog Pad.
"PROG" will blink in the Digital Display Window.



- Touch Memory Pad for the desired program.
The pad number and the previously programmed information will appear in the display. "PROG" will start to blink.



- Touch Double/Triple Quantity Pad once.
The previously selected magnification number will appear in the display.
[Example]: 1.6 times is "16". (Double quantity) 2.2 times is "22". (Triple quantity)



- Set the desired magnification by touching the appropriate Number Pad.
[Example]: 1.5 times; Touch Number Pads "1" and "5".



- Touch Prog Pad again.
The "PROG" will stop blinking. This means that you have completed programming the selected Memory Pad for appropriate double quantity.



- After 3 seconds later, "0" will appear.

Note: If you want to change appropriate time for triple quantity, you touch Double/Triple Quantity Pad twice as in Step 4 above. The magnification is preset. Each magnification must be programmed separately for alterations.

N.B. Test for correct times when setting the program to achieve correct temperatures.

How to Operate

G. Memory Pad Heating for Double/Triple Quantity Heating

Make sure the unit is properly programmed. (See page 16.)



1. Follow Steps 1-2 in "E. Memory Pad Heating" on page 15.



2. Touch Double/Triple Quantity Pad once.

Note: When you want triple quantity heating, touch Double/Triple Quantity Pad twice.

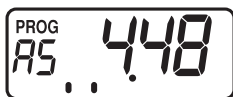

3. Touch the desired Memory Pad.

[Example]: Touch Memory Pad 5 (Program No. A-5).

Note: To use B or C side Program, touch Shift (A/B/C) Pad before touching Program Number Pad.



4. Touch Start Pad.

A. The oven lamp will turn on.

B. During operation, the indicator appears in order from the left.

C. The heating time will count down.

Note: If program lock is activated, the heating program starts immediately, i.e. there is no need to touch Start Pad. (See page 18.)



5. When all time has expired, the end of the cycle beep tone will sound. All heating will stop. The oven lamp will turn off. The time display will blink "0000" until the door is opened.



6. Open the door and remove the food. Close the door.
1 minute later the Digital Display Window will go blank.

H. +10s/+20s Pad Heating



1. Open the door.

The oven lamp will turn on. "0" will appear in the Digital Display Window.

Note: While "0" will appear, operation is available. 1 minute after the door is closed, "0" will disappear.

2. Put the food into a suitable container, place it in the centre of the oven and then close the door securely.
The oven lamp will turn off.

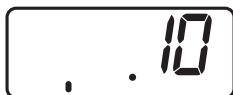

3. Touch +10s/+20s Pad once.

A. The oven lamp will turn on.

B. During operation, the indicator appears in order from the left.

C. Heating will start on P10 power for 10 seconds.

[Example]: Touch +10s/+20s Pad once for 10 seconds.

Touch +10s/+20s Pad twice for 20 seconds.



4. When all the time expires, the end of cycle beep tone will sound. All heating will stop. The oven lamp will turn off. The time display will blink "0000" until the door is opened. 1 minute later, cooling fan will stop.

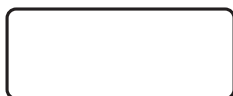

5. Open the door and take the food out.

The oven lamp will turn on.

6. Close the door.

The oven lamp will turn off and 1 minute later the Digital Display Window will go blank.

Note: While heating, one touch on Stop/Reset Pad or opening the door will cancel the heating program.

How to Operate

I. To Read the Cycle Counter

• To display total cooking hours ever used



1. Open the door and leave it open.
The oven lamp will turn on. "0" will appear in the display.



2. While touching Start Pad, touch Number Pad "3".
Total cooking hours ever used will appear.

• To display the total number of times ever using oven

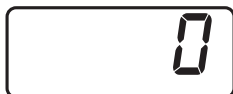

1. Open the door and leave it open.
The oven lamp will turn on. "0" will appear in the display.



2. While touching Start Pad, touch Power Level Selector Pad.
The total number of times ever using oven will appear.
Note: The maximum number of times on the counter will be 3,999,999. The last two digits are dropped and displayed in units of 100 when used over 100 times. For less than 100 times, "0" will be displayed.

J. To Activate Program Lock

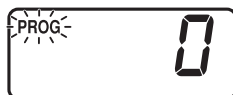

1. Open the door and leave it open.
The oven lamp will turn on. "0" will appear in the display. While touching Start Pad, touch Prog Pad until the display show "PROG", "P" and "L" (for more than 2 seconds).



2. Program Lock feature is now activated.
Note: In "Program Lock"
 - a. The oven is started by touching the desired Memory Pad. There is no need to touch Start Pad.
 - b. The Interrupt feature is deactivated—opening the door cancels the remaining time on the program.
 - c. The oven can not be programmed or run manually until the Program Lock feature is deactivated.

K. To Deactivate Program Lock

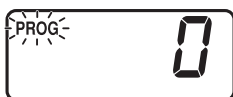

1. Open the door and leave it open.
The oven lamp will turn on. "0" will appear in the display. While touching Start Pad, touch Prog Pad until the Digital Display Window show "PROG" and "P" (for more than 2 seconds).



2. Program Lock feature is now deactivated.
Note: In "Program Unlock"
 - a. Oven reverts to a two-touch operating mode (Number/Memory Pad + Start Pad).
 - b. Repeat and interrupt features are operational.
 - c. Memory Pads can be programmed.
 - d. Manual heating is operational.
 - e. Tone loudness control, length control and pitch control (beep tone at the end of heating cycle/filter cleaning alarm) are operational.

How to Operate

L. To Read Program List



1. Open the door and leave it open.
2. While touching Start Pad, touch Number Pad "1".
All currently programmed information (the program set into each Number/Memory Pad (A0 to C9), Beep Tone, Program Lock, Oven Lamp settings when the door is open, Oven Lamp blink settings at the end of heating cycle and Oven Lamp reduction settings during cooking information) will continuously appear.
Note: When the filter cleaning alarm counter is set, this appears after Program Lock.

How to erase memory content

1. Open the door (keep it open) and touch Prog Pad.
2. Select the memory number you want to erase, and touch Power Level Selector Pad.
3. Touch Stop/Reset Pad, and "0" is displayed to indicate that memory is erased.
*Memory content is automatically erased if overwritten.

How to Operate

To Select Pitch of Tone

There are 3 options for the pitch of tone at the end of the heating cycle.

•: Low, ••: Normal (Factory Setting), •••: High



7. Within 3 seconds after touching Prog Pad at Step 6, touch Start Pad.

A. "PROG" will start to blink.

B. Current pitch of tone will be displayed.

C. The display changes to "•", "••", and "•••" each time Start Pad is touched and the settings change (Under the "bE" in "bEEP").



8. When the desired pitch of tone has been selected, touch Prog Pad again.

"PROG" will stop blinking, and the set pitch of tone at the end of heating cycle will appear for 3 seconds. Then "0" will appear.



To proceed to set pitch of filter cleaning alarm, touch Start Pad before "0" is displayed after Step 8.

To Select Pitch of Filter Cleaning Alarm

There are 3 options for the pitch of the filter cleaning alarm.

•: Low, ••: Normal (Factory Setting), •••: High



9. Within 3 seconds after touching Prog Pad at Step 8, touch Start Pad.

A. "PROG" will start to blink.

B. Current pitch of filter cleaning alarm will be displayed.

C. The display changes to "•", "••", and "•••" each time Start Pad is touched and the settings change (Under the "EP" in "bEEP").



10. When the desired pitch of filter cleaning alarm has been selected, touch Prog Pad again.

"PROG" will stop blinking, and the set pitch of filter cleaning alarm will appear for 3 seconds. Then "0" will appear.



Note: When the programmed hour for second stage of the air filter cleaning cycle is set to "0", the pitch of filter cleaning alarm can not be selected.

N. Procedure to Program the Air Filter Cleaning Cycle

The oven can not be programmed until the program lock feature is deactivated.

(See page 18, K. To Deactivate Program Lock.)



1. Open the door and leave it open.

The oven lamp will turn on. "0" will appear in the Digital Display Window.



2. While touching Start Pad, touch Number Pad "7".

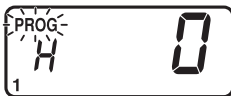

To Program the First Stage

3. The display will show the length of time (in hours) between cleaning the Air Filter you have programmed in or the original time preset by the manufacturer.

(Continued on next page.)

How to Operate



4. Set the desired cleaning cycle by touching the appropriate Number Pads. (Up to 9999 hours)
[Example]: Touch Number Pads “1”, “0” and “0” for 100 hours.



To Program the Second Stage

5. Touch Start Pad. The display will show the length of time (in hours) between cleaning the Air Filter you have programmed in or the original time preset by the manufacturer.



6. Set the desired cleaning cycle by touching the appropriate Number Pads. (Up to 9999 hours)
[Example]: Touch Number Pads “6”, “0” and “0” for 600 hours.



7. Touch Prog Pad.
This completes the procedure to program time between cleaning of the Air Filter.



8. After 3 seconds, “0” will appear in the Digital Display Window. The oven is now ready for use.

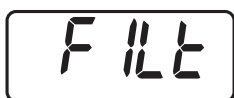

- Note:** When the total hours used reach the time for the first stage and the second stage, “FILT” sign appears in Digital Display Window and different beep tones will sound for each stage. Remove the Air Filter and clean it. (See page 6.) For the first stage, the same beep tone as after cooking will sound, and for the second stage, the filter cleaning alarm tone will sound. (See pages 20–21.)
- To clear the “FILT” sign after cleaning the filter, touch Stop/Reset Pad for 2 seconds until a long beep tone sounds. The counter will start over from “0” after it is cleared.



To display the filter cleaning alarm counter

1. Open the door and leave it open.
2. While touching Start Pad, touch Number Pad “5”.



After 3 seconds, “0” will appear in the Digital Display Window.



N.B. If the oven cuts out after short operation, check the Air Filter is clean before calling an engineer.

O. Oven Lamp

The oven can not be programmed until the program lock feature is deactivated. (See page 18, K. To Deactivate Program Lock.)

•Oven Lamp settings when the door is open

To turn Oven Lamp settings OFF



1. Open the door and leave it open.
The oven lamp will turn on, and “0” will appear.

(Continued on next page.)

How to Operate



2. While touching Start Pad, touch Number Pad "9".
"PROG" will start to blink. The previously set Oven Lamp settings are displayed.



3. Touch Start Pad.
Note: "on" → "oFF" → "on" is repeated each time the Pad is touched.



4. Touch Prog Pad.
"PROG" will stop blinking, and the Oven Lamp settings will appear for 3 seconds.
Then "0" will appear.



To proceed to Step 5, touch Start Pad before "0" is displayed after Step 4.

•Oven Lamp blinks at the end of heating cycle

To turn the blinking Oven Lamp ON at the end of heating cycle



5. Within 3 seconds after touching Prog Pad at Step 4, touch Start Pad.
"PROG" will start to blink. The previously set Oven Lamp blink settings are displayed.



6. Touch Start Pad.
Note: "oFF" → "on" → "oFF" is repeated each time the Pad is touched.



7. Touch Prog Pad.
"PROG" will stop blinking, and the Oven Lamp blink settings will appear for 3 seconds. Then "0" will appear.

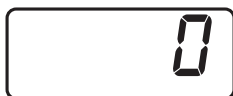

To proceed to Step 8, touch Start Pad before "0" is displayed after Step 7.

•Adjusting Oven Lamp brightness during cooking

To decrease brightness of the inner cavity during cooking



8. Within 3 seconds after touching Prog Pad at Step 7, touch Start Pad.
"PROG" will start to blink. The previously set Oven Lamp reduction settings are displayed.



9. Touch Start Pad.
Note: "oFF" → "on" → "oFF" is repeated each time the Pad is touched.



10. Touch Prog Pad.
"PROG" will stop blinking, and the Oven Lamp reduction settings will appear for 3 seconds. Then "0" will appear.



Before Cooking

Microwave Basics

Fundamental principles determine the success of microwave food preparation.

They include:

1. **Temperature of Foods**—Frozen or refrigerated food items will require longer heating times to reach a desired serving temperature than foods from room temperature.
2. **Food Components**—Foods high in sugar, salt, fat and moisture content heat faster because these properties attract microwave energy. Denser foods high in protein and fibre, absorb microwave energy slower which means a lengthier heating time.
3. **Bulk/Volume**—The greater the mass of food, the longer it takes to heat.
4. **Containers**—Ceramic, paper, china, styrofoam, glass and plastic are suitable for use in microwave ovens with the following caution:

Heating foods with either high sugar or high fat content should be done **ONLY** in high temperature-resistant containers since these foods get very hot. Using styrofoam containers for these foods will cause the styrofoam to warp. Other low temperature restaurant glass or plastic platters may crack or warp under similar conditions.

DO NOT HEAT foods in a **SEALED** container or bag. Foods expand when heated and can break the container or bag.

5. **AVOID METAL** because it “bounces” the microwaves, causing uneven heating and sometimes even flashes, which may pit or mark the interior of the oven, the metal container or plate trim.
6. Heated liquids can erupt if not mixed with air. Do not heat liquids in your microwave oven without first stirring.

General Guidelines for Heating in a Microwave Oven

For specific time, see each food category for appropriate heating techniques, plus necessary pre-preparation of foods.

Heating Foods from Refrigerated Temperature

Foods stored in the refrigerator (5°C) should be covered before reheating with the exception of breads, pastries or any breaded product, which should be heated uncovered to prevent sogginess.

Most conventionally prepared foods should be slightly undercooked, and stored in the refrigerator, so that overcooking does not occur during microwave heating.

Cooked items, such as vegetables, may be portion plated and covered for reheating without loss of colour, texture or nutritional content.

Heating Foods from Room Temperature

Food items such as canned entrees, vegetables, etc. will require significantly less heating time than those at refrigerated temperatures.

Important Recommendations

1. For best results it is recommended that foods conventionally prepared be slightly undercooked when subsequently heated in this oven.
2. **REMEMBER** that after the heating cycle has been completed, internal food temperatures continue to rise slightly in foods heated in this oven.
3. A major abuse of microwave applications is the category of breads, pastries and pies. They are drier than insides or fillings, they heat more slowly. Therefore, baked goods should **ONLY** be heated until the crust is warm to the touch (50°C–55°C).
4. **DO NOT OVERHEAT YOUR FOOD:** 99% of all food quality complaints of microwave heated foods can be traced to overheating.

Cooking Instructions – Heating and Defrosting Time Charts –

The times given in the chart below are a **guideline only**. Many factors e.g. **starting temperature** of the food can affect the final heating time required. The cooking and defrosting times must be adjusted when necessary. All times are tested using foods at **starting temperatures** as below;

Chilled foods.....Approx. +5°C

Frozen foods.....Approx. –18°C

Always check for the correct core temperature with a temperature probe to comply with current Government Food Hygiene Regulations.

Function	Food	Weight	Power Level	Approx. Time		
				NE-1866	NE-1566	
Defrosting	Fish Fillets	500 g	DEFROST (P1)	8 min		
	Minced Beef	500 g	DEFROST (P1)	5 min		
	Whole Chicken	1.36 kg	DEFROST (P1)	25 min		
	Composite Dish	Multi portion	1.36 kg	DEFROST (P1)	20 min	
		Single portion	275 g	DEFROST (P1)	8 min	
	Apple Pie	1 portion	DEFROST (P1)	1 min 15 sec		
	Gateau	1 portion	DEFROST (P1)	2 min		
	Bread Rolls	1 portion 50 g	DEFROST (P1)	30 sec		
Cooking Chilled Raw Food	Scrambled Egg	2 eggs + 2 tbsp. milk	MEDIUM (P5)	1 min 30 sec Stir halfway.	1 min 50 sec Stir halfway.	
	Broccoli	500 g	HIGH (P10)	2 min 30 sec	3 min	
	Bacon	2 rashers	HIGH (P10)	50 sec	1 min	
	Chicken Portions	500 g	MEDIUM HIGH (P7)	4 min 30 sec	5 min 30 sec	
	Chicken Fillets	500 g	MEDIUM HIGH (P7)	3 min 30 sec	4 min 15 sec	
	Fish Fillets	500 g	MEDIUM HIGH (P7)	2 min 45 sec	3 min 15 sec	
	Fish Fillets	100 g	LOW (P3)	3 min	3 min 30 sec	
	Cooking and/or Reheating Frozen Food	Peas	500 g	HIGH (P10)	3 min 30 sec	4 min 15 sec
Cooked Rice		167 g	HIGH (P10)	1 min 20 sec	1 min 40 sec	
Cooked Sausage		x 3 (50 g each)	HIGH (P10)	50 sec	1 min	
Cooked Chicken Wings		x 7 pieces	HIGH (P10)	1 min 20 sec	1 min 40 sec	
Cooked Boxed Cheeseburger		75 g	HIGH (P10)	50 sec	1 min	
Lasagne		325 g	HIGH (P10)	4 min	4 min 45 sec	
Fondant au Chocolat		100 g	LOW (P3)	50 sec	1 min	
Chocolate Fudge Cake		1 portion	DEFROST (P1)	30 sec	40 sec	
Reheating Chilled, Cooked Food	Lasagne	325 g	HIGH (P10)	2 min 30 sec	3 min	
	Chilli	325 g	HIGH (P10)	2 min	2 min 20 sec	
	Apple Pie	1 portion	HIGH (P10)	16 sec	20 sec	
	Pepper Sauce	100 ml	HIGH (P10)	50 sec	1 min	
	Baked Beans	100 ml	HIGH (P10)	50 sec	1 min	
	Soup	125 ml	HIGH (P10)	42 sec	50 sec	
	Creamy Soup	200 ml	MEDIUM HIGH (P6)	1 min	1 min 10 sec	

Cooking Instructions – Heating and Defrosting Time Charts –

Function	Food	Weight	Power Level	Approx. Time	
				NE-1866	NE-1566
Other	Melt Chocolate	500 g	MEDIUM (P4)	2 min 30 sec Stir halfway.	3 min Stir halfway.
	Melt Butter	50 g	LOW (P3)	1 min 40 sec	2 min
		500 g Cut into 3 cm cube.	MEDIUM HIGH (P6)	2 min -2 min 30 sec	2 min 20 sec - 3 min
		50 g	LOW (P3)	1 min	1 min 10 sec

- HINTS:**
- Do not cook/reheat/defrost directly onto the base of the oven — use a suitable container.
 - When defrosting **multi portions** of foods, turn over and break apart halfway through defrost time to allow better penetration of microwave energy.
 - **Solid/dense foods** should not be cooked from frozen as they will be overcooked round the edges before the centre has reached the required temperature.
 - **Cover** dishes where appropriate during cooking/reheating. This will retain moisture and prevent splashing/spillages.
 - Loosen lids/pierce clingfilm before cooking/reheating covered foods.
 - **Stir** or **shake** foods halfway through cooking/defrosting time to distribute the heat evenly.
 - Allow a **Stand Time** before food temperature is checked and/or offered for consumption.

Self Diagnostics Failure Code Explanation

This oven monitors its operation and displays a Failure Code in the Digital Display Window when a problem occurs.

CODE	PROBLEM
rFL	Splatter shield is removed. Place it back. The oven is inoperative without it.
U30	Memory cooking with double/triple quantity has exceeded the maximum cooking time. Check and change the time. (See Step 3 “Note” on page 15.) Press Stop/Reset Pad, and the code disappears.
U40	The temperature of electrical parts is too high. If the oven was operated without food, please put the food into the cavity and heat it. Press Stop/Reset Pad, and the code disappears.
F09	The oven is connected to 60 Hz. Connect to 50 Hz.
F code other than F09 (F97, etc.)	If the “F” code does not disappear even after pressing Stop/Reset Pad, pull out the plug and then plug it in again after 5 seconds. The oven is faulty if the “F” code still appears. Unplug the oven or shut off the power at the circuit breaker, and contact the dealer or a service agent.

Specifications

		NE-1866	NE-1566
Power Source		50 Hz, single phase 230–240 V	
Required Power		11.6 A 2650 W	9.5 A 2370 W
Output*	HIGH	P10: 1800 W*	P10: 1500 W*
	MEDIUM HIGH	P9: 90% P8: 80% P7: 70% P6: 60%	
	MEDIUM	P5: 50% P4: 40%	
	LOW	P3: 30% P2: 25%	
	DEFROST	P1: 340 W	
	OFF	P0: 0%	
	HEAT FROM TOP DOWN	PU1: 50% PU2: 25%	
	HEAT FROM BOTTOM	PL1: 50% PL2: 25%	
Frequency		2450 MHz	
Outside Dimensions (W × D × H)		422 mm × 476 mm × 337 mm	
Cavity Dimensions (W × D × H)		330 mm × 310 mm × 175 mm	
Net Weight		Approx. 17.9 kg	
Timer		Maximum programmable time for single stage heating P1 and P0=30 minutes P10–P2, PU1–PL2=15 minutes	

***IEC Test Procedure**

Specifications subject to change without notice.

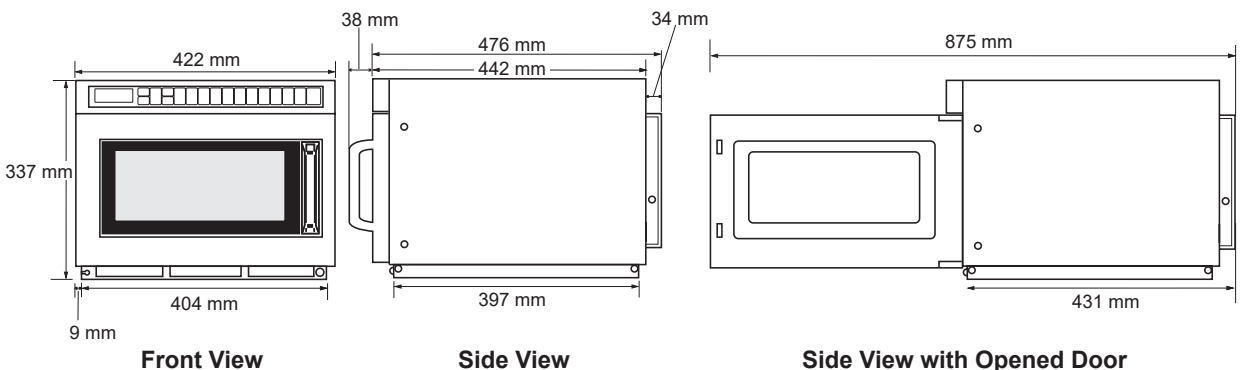

Panasonic Kitchen Appliances Technology (Jiaxing) Co., Ltd.

Website: <https://www.panasonic.com>

© Panasonic Kitchen Appliances Technology (Jiaxing) Co., Ltd. 2026

F00033J90QP

H0226-0

Printed in China