

PIZZA/SANDWICH PREP BENCH



SUR 1871HPZ- (AUH)

Pizza/Sandwich Prep Bench

HEIGHT (MM)*	1150
TOTAL LENGTH (MM)	1800
DEPTH (MM)	800
NET VOLUME (L)	410
WEIGHT (KG)	140
PLUG TYPE AMPERAGE	10A



- Top mount Cutting Board
- High-quality stainless steel
- Operates reliably in ambient temperatures up to 40°C with a wide temperature range (1~+5°C).
- Designed for easy cleaning
- Anti-bacteria handles and shelves
- 9x 1/9 GN trays for maximum flexibility
- Removable 300mm x 15mm thick cutting board
- Castors as standard
- 2 year parts and labour warranty
- 2 Part top cover
- Insulated Hinged lid

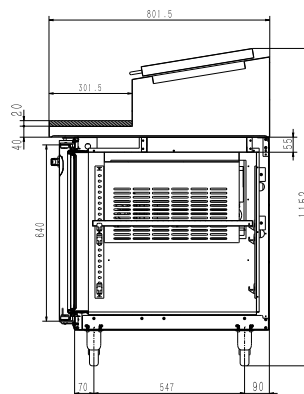
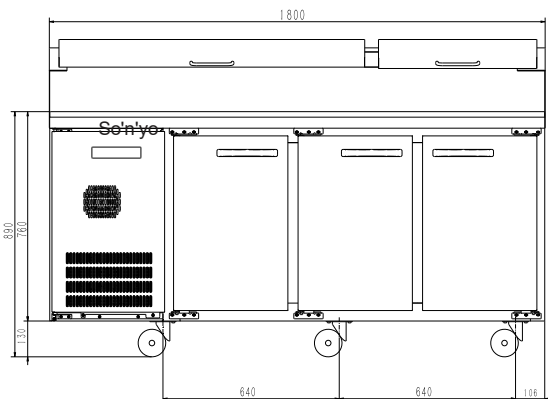

LED Lighting



Forced Evaporation



220-240V Single Phase



Heater Defrost



Castors Standard Legs optional



2 Year Parts & Labour Warranty