

SELF CONTAINED

ARCH SERIES

MODULAR DUAL TEMP ISLAND CABINETS



ENHANCED ENERGY EFFICIENCY
& VERSATILITY

HUSSMANN[®]

microSC[™]



PRODUCT BENEFITS

- Ergonomic design for easy product access
- Flexible shelving configurations to optimise merchandising
- Best visual impact for products with energy efficient LED lighting
- Low Total Energy Consumption to save on total energy costs
- Ensured product temperature compliance tested
- Designed for modular configurations to suit many store formats
- Small footprint with maximised display area
- Reinforced shelving to suit varied product weight
- Environmentally sustainable design using natural refrigerant
- Adjustable feet for easy levelling installation
- Easy plug-in on-site installation
- Low reflective E-coated glass for improved product visibility and temperature control
- Flexible dual temperature cabinet (LT and MT) that easily changes from freezer to chiller to provide optimised merchandising to meet customer demand
- Bottom front drainage opening for easy cleaning
- Also Available, the Arch Plus, an optional dual-temperature, vertical add-on to the Arch Series, allowing for space-efficient multi-zone merchandising.

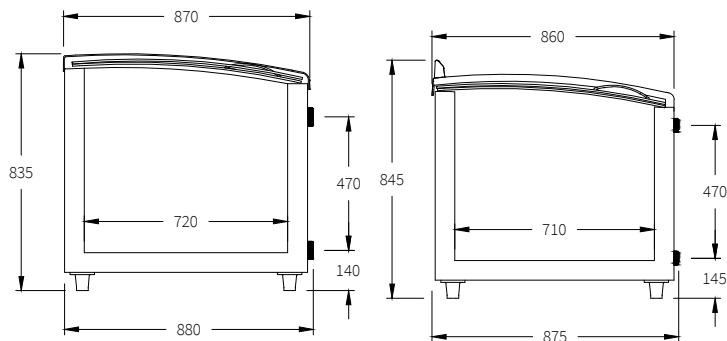

ARCH250-DT
ARCH220-DT
ARCH170-DT

ARCH194C-DT

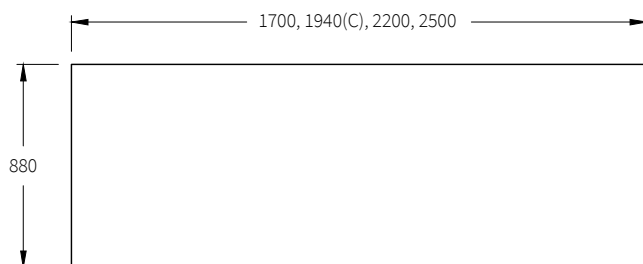

STANDARD FEATURES

- External and internal food grade plasticised metal sheet finish
- Single horizontal front mounted 5700K LED light
- Ticket strips
- Rubber bumper (black)
- Static refrigeration system with copper evaporator
- Digital controller with temperature display
- Ventilated condensing unit
- Glass sliding doors
- Automatic hot-gas defrost
- Dividers and shelves provided based on length (1700 - 2/3, 2200 - 3/4, 2500 - 4/5, 1940 - 3/4)
- Refrigerant: R290
- EC fan motors

CUSTOMISATIONS

Shelving & Base Shelf

- Additional shelves and dividers
- Baskets

Lighting

- Additional rear mounted LED lighting available

Other

- Castors
- Brushed stainless steel kickplate
- Rear metal joining kit for island configurations
- Other foot heights available (75mm, 110mm)
- Alternative bumper colour options available
- External and internal colours available on request



Energy & Sustainability

- ARCH-VS series with variable speed compressor (inverter)
- Modbus ready

TECHNICAL DATA

CODE	Standard Depth 880mm	Standard Height 835mm	ARCH250-DT	ARCH220-DT	ARCH170-DT	ARCH194C-DT
Total Length (mm)			1700	2200	2500	1940 (crown)
Net Volume (L)			411	1603	677	452
Display Area (m ²)			0.97	2.97	1.5	1.19

TEMPERATURE CLASS

3M1	3L1
	
(-1 °C to +5 °C)	(-18 °C to -15 °C)

Additional Information

All Dimensions shown in Millimetres (mm) unless otherwise stated. Dimensions and features are subject to change. Please obtain current technical information prior to order confirmation.

NOTE: We reserve the right to change or revise specifications and product design in connection with any feature of our products. Such changes do not entitle the buyer to corresponding changes, improvements, additions or replacements for equipment previously sold or Shipped.

© 2021 Hussmann Corporation - Version - V.1.0

Australia Head Office

66 Glendenning Road Glendenning, NSW 2761 Australia

ph. +612 8805 0400

w. www.hussmann.com.au

HUSSMANN®