

GEMINI

PLUG IN TOTAL MODULARITY



GALILEI
REFRIGERAZIONE & DESIGN

GEMINI È ESPRESSIONE DEL PROGETTO **VI.DE.RE.** VISIBILITY, DESIGN, RELIABILITY

GEMINI HAS BEEN DEVELOPED ACCORDING TO PROJECT **VI. DE. RE.**
VISIBILITY, DESIGN, RELIABILITY

GEMINI EST L'EXPRESSION DU CONCEPT **VI. DE. RE.**
VISIBILITÉ, DESIGN, FIABILITÉ

GEMINI WURDE IM RAHMEN DES PROJEKTES **VI. DE. RE.**
ENTWICKELT VISIBILITY, DESIGN, RELIABILITY

GEMINI HA SIDO DESARROLLADO DE ACUERDO AL PROYECTO **VI. DE. RE.**
VISIBILIDAD, DISEÑO, FIABILIDAD



Gemini 120 VD 1250



Gemini 120 VC 1250



Gemini 120 VD GD 2500



Coperture scorrevoli
Glass lids
Couvercles vitrés
Glass Deckel
Tapas de cristal



TRASPARENZA DELLE SUPERFICI
Per una visione completa di tutta la merce esposta

RIGORE DELLE FORME
Forme semplici, merce in primo piano

PIÙ PRODOTTO ESPOSTO
Per metro quadrato di superficie grande capacità di carico con ingombri ridotti

FACILITÀ DI INTEGRAZIONE
In ogni tipologia di negozio possibilità di combinare più mobili.

COMPLETE TRANSPARENCY
Of the upper section, allowing for excellent visual merchandising

SIMPLE AND SHARP LINES
Sober and elegant shapes, product in foreground

HIGHEST FOOTPRINT PRODUCTIVITY
More food in a small cabinet

EASY TO INTEGRATE
In any store format

TRANSPARENCE TOTALE
Visibilité parfaite des denrées exposées

DESIGN ÉPURÉ
Esthétique sobre et élégante, mise en avant des denrées

TRÈS BONNE RENTABILITÉ
Grand volume de chargement par rapport à l'emprise au sol

FACILITE D'INTEGRATION
Adapté à tout type de magasin

EINE VOLLSTÄNDIGE TRANSPARENZ
Im oberen Bereich erlaubt eine exzellente Warenpräsentation

EINFACHE UND KLARE FORMEN
Sowie ein schlichtes und elegantes Design lässt die Ware im Vordergrund stehen

HÖCHSTE WARENPRÄSENTATIONSFÄHIGKEIT
Mehr Ware in kleinen Möbeln

LEICHT ZU INTEGRIEREN IN ALLEN LADENFORMATE
Anreihfähig

TOTAL TRANSPARENCIA
Permitiendo una vision excelente de todo el producto

LINEAS SIMPLS, RIGUROSAS
Formas sobrias y elegantes, para mostrar el producto en primer plano

MÁS PRODUCTO EXPUESTO
Por ocupación en suelo

FACILIDAD DE INTEGRACIÓN
A cualquier tipo de negocio

CONSUMI ENERGETICI RIDOTTI
Valvola termostatica, ventilatori elettronici, alto isolamento termico, dimensionamento generoso dell'evaporatore

LUNGA DURATA DEL BANCO
Lamieraggi interni in acciaio zincato e verniciato a polveri, evaporatore protetto contro la corrosione, componenti di prima qualità

BASSI COSTI DI INSTALLAZIONE
Protezione elettrica magneto-termica e differenziale di serie

FACILITÀ DI PULIZIA
Componenti facilmente smontabili

REDUCED ENERGY CONSUMPTION
Expansion valve, EC-fans, highest thermal insulation, big evaporator

LONG LIFE OF THE CABINET
All metal parts inside the case in galvanized and fully coated steel, evaporator protected against corrosion, first quality components

LOW INSTALLATION COSTS
The RCBO switch in the standard equipment

SIMPLE TO CLEAN
All components easy to disassemble

CONSUMAZIONE TRÈS FAIBLE
Détendeur thermostatique à égalisation externe de pression, ventilateurs électroniques, évaporateurs de grande taille, isolation renforcée, compresseurs parfaitement adaptés

GRANDE LONGÉVITÉ
Composants techniques de grande fiabilité et construction très soignée

FAIBLE COUT D'INSTALLATION
La protection électrique différentielle est intégrée dans la vitrine

GRANDE FACILITÉ DE NETTOYAGE
Tous les composants se démontent très facilement

REDUZIERTER ENERGIEVERBRAUCH
Thermostatische Expansionsventile, hervorragende Dämmung, große Verdampfer

LANGE LEBENSDAUER DES MÖBELS
Alle Metallteile im Inneren des Gehäuses aus verzinktem und vollständig pulverbeschichtetem Stahl, Verdampfer gegen Korrosion geschützt, erstklassigen Komponenten

GERINGE INSTALLATIONS-AUFWAND
FI-Schutzschalter (Personenschutz) ist Standard

EINFACHE REINIGUNG
Alle Komponenten sind einfach zu demontieren

REDUCIDO CONSUMO ENERGÉTICO
Válvula termostática, ventiladores ec, alto aislamiento térmico, generoso evaporador

MUEBLE DE MÁS LARGA VIDA
Todas las partes metálicas internas en acero galvanizado y barnizadas al polvo, evaporador protegido a la corrosión, componentes de alta calidad

BAJO COSTE DE INSTALACIÓN
Magnetotérmico y diferencial incluidos

FACILIDAD DE LIMPIEZA
Todos los componentes son de fácil extracción

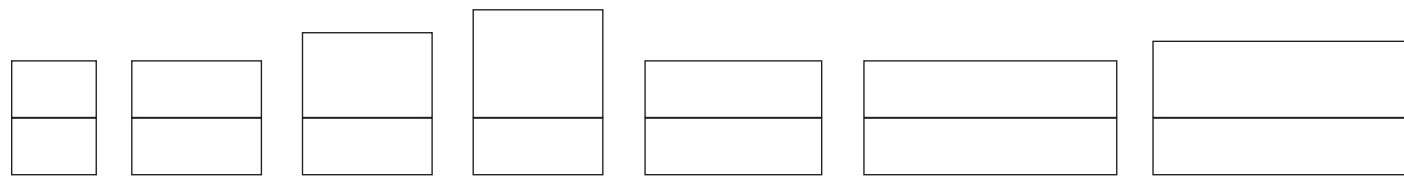

GALILEI PLUG IN TOTAL MODULARITY

1 PROGETTO

4 MODELLI

40 MODULI

∞ COMBINAZIONI

MASSIMA ADATTABILITÀ

Ingombri ridotti, forme moderne, disponibilità di più taglie

MAXIMUM ADAPTABILITY

Reduced dimensions, modern shapes, several sizes available

ADAPTABILITE MAXIMALE

Dimensions réduites, design contemporain, disponible dans plusieurs tailles

VIelfalt

Optimierte Abmessungen, einfache Formen, breite Auswahl an Modulen

MÁXIMA ADAPTABILIDAD

Cornisa reducida, líneas modernas, otras medidas disponibles



Gemini 120 D 2500



Controllore elettronico
Control panel
Régulateur électronique
Elektronische Steuerung
Controlador electrónico

GALILEI PLUG IN TOTAL MODULARITY

1 PROJECT

4 MODELS

40 MODULES

∞ COMBINATIONS

GALILEI PLUG IN TOTAL MODULARITY

1 PROJET

4 MODELES

40 MODULES

∞ COMBINAISONS

GALILEI PLUG IN TOTAL MODULARITY

1 PROJEKT

4 MODELLE

40 MODULEN

∞ KOMBINATIONEN

GALILEI PLUG IN TOTAL MODULARITY

1 PLATAFORMA

4 FAMILIAS

40 MODELOS

∞ COMBINACIONES

PERSONALIZZAZIONI

Base e interni disponibili in più colori, piedi e rivestimenti disponibili in più soluzioni

CUSTOMIZATION

Base and inner parts available in several colours, feet and claddings available in different solutions

PERSONNALISATION

Soubassement et intérieur disponibles en plusieurs couleurs, pieds et revêtements disponibles en plusieurs solutions

KUNDENINDIVIDUELL

Unterbauten und Auslagen in mehreren Farben und Varianten verfügbar.

PERSONALIZABLE

Color de cuba, patas y faldones standard y a medida

GEMINI, DOPPIA ESPOSIZIONE

GEMINI
DOUBLE PRESENTATION

GEMINI
DOUBLE PRESENTATION

GEMINI
BEIDSEITIGE PRÄSENTATION

GEMINI
PRESENTACIÓN DOBLE

	Lunghezza (senza spalle) Length (without ends) Longueur (sans joues) Länge (ohne Seitenwände) Longitud (sin laterales)	Refrigerante Refrigerant Réfrigérant Kältemittel Refrigerante	Classe di temperatura Temperature class Classe de température Temperaturbereich Clase climática		Superficie espositiva Max. display area Surface max. d'exposition Maximale Auslagefläche Máxima superficie de exposición	Capacità di carico Volume capacity Volume utile Nutzinhalt Volumen útil
	mm			*GD	m ²	dm ³
Gemini 120 VC	1250	R290	3M2	-	1,50	300
Gemini 120 VD	1250	R290	3M2	3M1	1,50	300
Gemini 120 Maxi	1250	R290	3M2	3M1	1,50	375
Gemini 120 D	1250	R134a	3M2	-	2,25	338

* GD = con coperture vetro /with glass lids / avec couvercle vitrés / mit Glasdeckel / con tapas de cristal

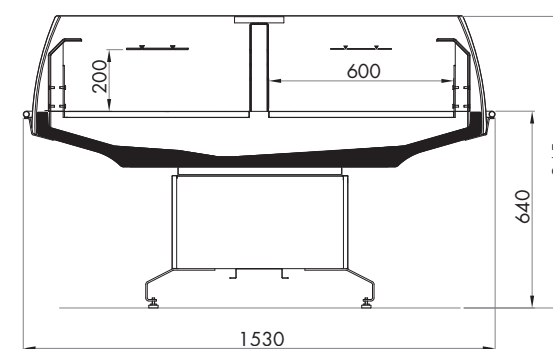

GEMINI 120 VC

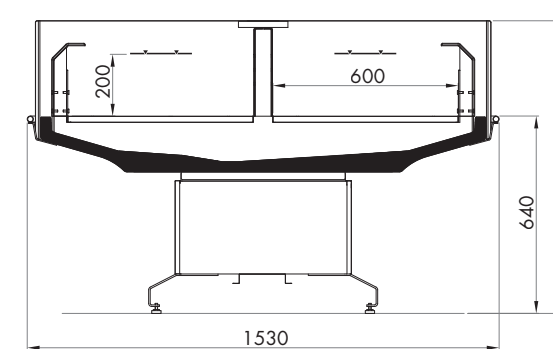

GEMINI 120 VD

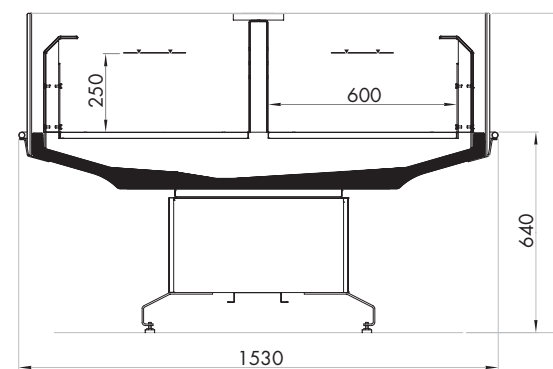

GEMINI 120 MAXI

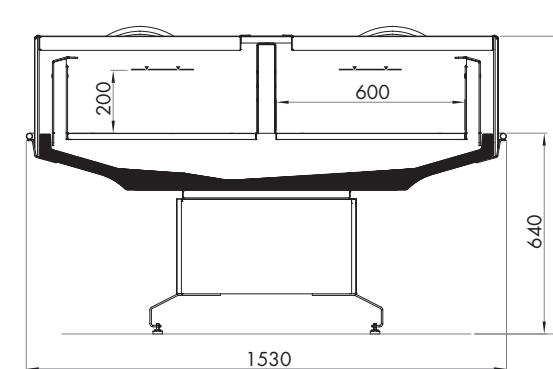

GEMINI 120 VD GD

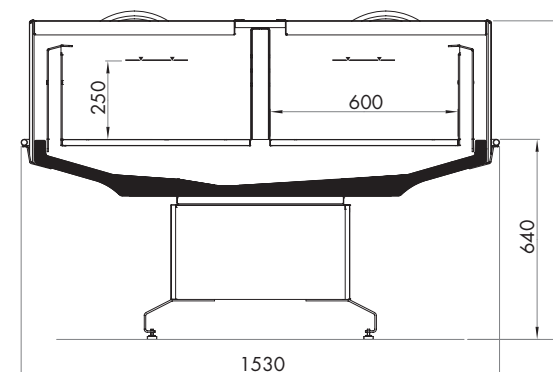

GEMINI 120 MAXI GD

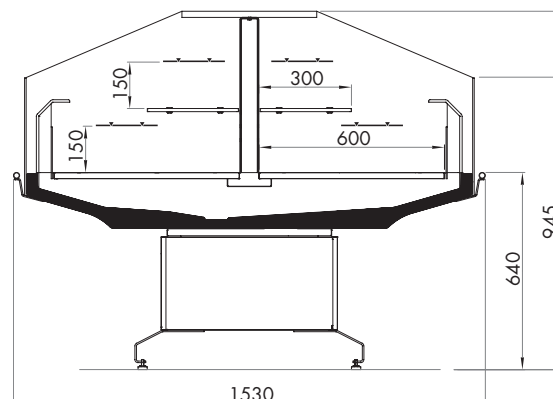

GEMINI 120 D

Biologico

LE OFFERTE
DEL GIORNO

~ Pasticcio ~
~ Involtini ~
~ Salumi ~

Cibi pronti

GALILEI PLUG IN LINE

1
PROGETTO

4
MODELLI

40
MODULI

∞
COMBINAZIONI

VI
VISIBILITY
DE
DESIGN
RE
RELIABILITY

