

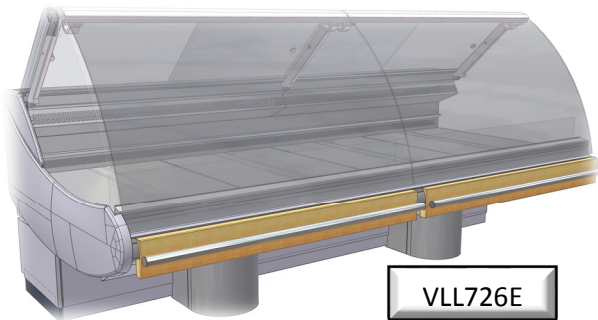

SPECIALTY CASE FACILITY

# VLL726E/VLL726BL/VLL727BL/VSS726E/VVS727E REFRIGERATED DISPLAY CABINETS ENHANCED MODELS



VLL726E

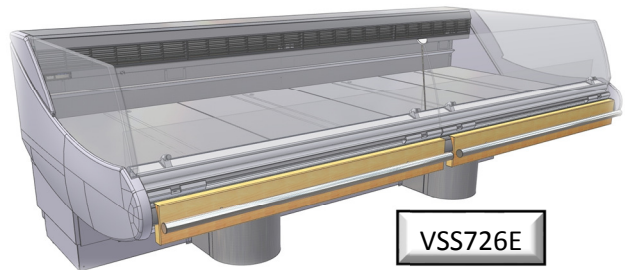

VSS726E

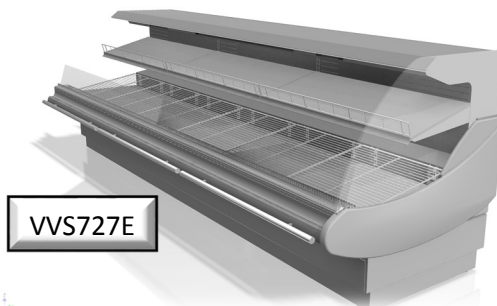

VVS727E

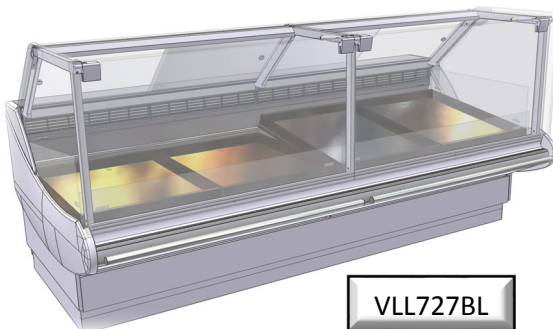

VLL727BL

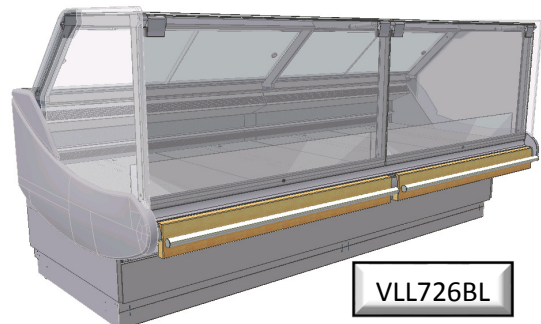

VLL726BL

## INSTALLATION AND MAINTENANCE INSTRUCTIONS

MAN147/1

April 2013

**HUSSmann**<sup>®</sup>  
Specialty

# CONTENTS

<b>AMBIENT OPERATING CONDITIONS .....</b>	<b>3</b>
<b>LOCATION CONDITIONS .....</b>	<b>3</b>
<b>KEY OPERATION POINTS .....</b>	<b>4</b>
<b>RECEIVING CABINETS .....</b>	<b>4</b>
<b>CABINET INSTALLATION .....</b>	<b>5</b>
• <b>JOINING CABINETS</b>	
• <b>BASE OPTIONS</b>	
• <b>KITS</b>	
• <b>ATTACHING THE FRONT BUMPER</b>	
• <b>ADJUSTING FRONT GLASS</b>	
• <b>ELECTRICAL INSTALLATION</b>	
• <b>DRAIN INSTALLATION</b>	
• <b>PRE-START CHECK LIST</b>	
<b>CABINET OPERATION .....</b>	<b>13</b>
• <b>LOADING LIMITS</b>	
• <b>FITTINGS AND ACCESSORIES</b>	
• <b>TEMPERATURE CHECKING</b>	
<b>MAINTENANCE .....</b>	<b>19</b>
• <b>CLEANING</b>	
• <b>REGULAR INSPECTION</b>	
• <b>DISPOSAL OF THE CABINET</b>	
• <b>REPLACEMENT PARTS</b>	
<b>CABINET SECTIONAL VIEWS .....</b>	<b>21</b>
<b>CABINET JOINING DIAGRAMS .....</b>	<b>26</b>
<b>CABINET FOOTPRINTS .....</b>	<b>29</b>
<b>HAZARD ASSESSMENT .....</b>	<b>33</b>

## **AMBIENT OPERATING CONDITIONS**

All “V” series Refrigerated Display Cabinets have been designed to operate under the following conditions:

### Class 3M1

Ambient temperature	25°C
Relative humidity	60%
Max cross draft	0.2 m/sec
Product Temperature	-1°C to +5°C

### Class 3M0 (VVS727E Cabinet – with shelf in angled position only)

Ambient temperature	25°C
Relative humidity	60%
Max cross draft	0.2 m/sec
Product Temperature	-1°C to +4°C

**Ambient conditions greater than those stated may result in poorer performance of the cabinet and higher running costs.**

## **LOCATION CONDITIONS**

Cabinets should be sited so that external influences are minimized. Situations to avoid are:

- Air draughts from: Air conditioning, Ventilation, Heating outlets, Entranceways,
- Heat sources: Sunlight, Spotlights, Hot cabinets, Concentrated external lighting, Non-insulated roofs and walls,
- Mechanical damage: Shopping trolleys, Forklift trucks, Pallet jacks, Floor polishers,

Extra protection may be required to minimize damage.

**Any of these situations could prevent this cabinet from performing correctly.**

**NOTE: Unless specified, there should be a 100mm gap between the cabinet and a wall. This is to allow sufficient airflow to prevent condensation**

## **KEY OPERATION POINTS**

- Always keep rear doors closed when not using the cabinet
- Do not overload the cabinet with product (see loading limits pp 13~16)
- Do not block air delivery or air return vents
- Do not add display ice to VLL726E and VSS726E cabinets. This will cause fan motor damage. VLL727E cabinets are designed for display ice.
- Do not use mechanical devices or other means to accelerate the defrosting process, other than those recommended by the manufacturer.
- Do not use electrical appliances inside the food storage compartments of the appliance, unless they are of the type recommended by the manufacturer.
- Always clean cabinet as described in the cleaning section of this manual and on the cleaning instruction label on the cabinet.
- **However, if a liquid spill should occur, the spill should be cleaned as soon as practicable. Liquids can be acetic, and if left will risk damage to some components in the cabinet.**

## **RECEIVING CABINETS**

Cabinets will always be dispatched in good condition. Always inspect the cabinet and packaged accessories for damage. Note any damage on the carrier's consignment note prior to signing.

For concealed damage that is found later, notify McAlpine Hussmann in the relevant country within 3 working days. Any issues will be addressed and rectified as applicable.

Australia:                   McAlpine Hussmann Ltd  
Email: mhl\_helpdesk\_au@hussmann.com  
Ph. 1300 36 38 40

New Zealand:               McAlpine Hussmann Ltd  
Tauranga  
Ph. 07 578 0965

**NOTE: A photographic record of any damage found is required.  
Also quote cabinet serial number and a brief description of the damage.**

A check should also be made to ensure:

- That all loose parts listed on the outside packaging are present and undamaged,
- That glass has not moved during shipment. Test any lifting glass carefully to ensure there is no rubbing or knocking of glass that may cause future damage. There are glass adjustment instructions in this manual

**NOTE: Any shortages will follow the same procedure as concealed damage.**

# **CABINET INSTALLATION**

## **JOINING CABINETS**

**Cabinets shall be installed level front to back and side to side to allow correct operation of lifting glass, and allow condensate to drain freely.**

**There is a 150 psig Dry Nitrogen (+/- 10psig) holding charge in the evaporator coil, please check the pressure before safely releasing the holding charge. If Dry Nitrogen holding charge is found to be below 140 psig, please undertake additional leak checks of the evaporator coil.**

1. Always identify the highest point on the floor where the cabinets are to be installed. Cabinets will need to be levelled from this point.
2. Mark a line on the floor that shows the position of the rear skid rail for the line-up.
3. Position the first cabinet, level end to end and front to back. Ensure the footbolts are adjusted (50mm nominal adjustment range) to accommodate the highest point in the floor. All footbolts must be adjusted to the floor. This will ensure hinged glass maintains its position over time as the cabinet settles.
4. Apply a non-hardening, flexible sealant to the end of the cabinet to ensure a seal between the refrigerated area of the cabinet and the ambient environment.
5. It is advisable to apply masking tape to any visible joints to be sealed later, before butting up the adjacent cabinet.
6. Place the next cabinet as close as possible to first cabinet and set the height of the second cabinet to roughly match the first following the procedures in steps 3, 4, and 5.
7. Push the cases together and insert joining bolts. Make any minor adjustments to exactly align the two cabinets and tighten the joining bolts.
8. Check cabinet is level from end to end and front to back at both ends.
9. Repeat procedures until all cabinets are aligned.
10. Apply finishing sealants and any jointer items. Remove masking tape from sealed joints. Tidying up any excess sealant.
11. Fit bumper assemblies. Detailed instructions are on the following page.
12. Check all glass gaps on lift front cabinets. Adjust as required to have a 3mm gap between each glass. A larger gap can be closed using a wiper strip adjacent to ends on box cabinets.
13. Fit wiper strips to the ends of box cabinets where required to close any glass gaps. Use RTV to glue to glass
14. After all services have been installed and completed, fit coving angles and dress panels.
15. Clean the condensate deck of any filings and rubbish that may have accumulated during installation. These may block drains or cause rust damage to panels over time.
16. Fit any internal panels that have been removed for installation.
17. Fit all supplied accessories. A list of separately wrapped loose items should be on the cabinet

**NOTE: The front glass may be packed loose in VSS726E and VVS727E cabinets.  
NOTE: There are joining diagrams at the back of this manual.**

## BASE OPTIONS

These cabinets are supplied as standard with removable base extensions. This allows the cabinet to be sited on a plinth and still maintain the optimum access and working height for the cabinet. A full set of panels should be supplied with each cabinet to make this change. If they are not included, contact McAlpine Hussmann for the required panels and instructions.

## KITS

There are also various kits to change cabinet configurations. Instructions for the fitting of these will be supplied with each kit. Contact Hussmann for kit options and instructions.

## ATTACHING THE FRONT BUMPER

**IMPORTANT! Bumper assembly securing screws must be fitted to all bumper assemblies.**  
**Bumper assemblies are sent unattached for transport reasons. Therefore, securing them correctly to prevent dislodgement and possible injury is very important.**  
**The following instructions should be followed carefully.**

1. Unwrap the bumper assembly. You should find a pre-assembled bumper assembly and a number of securing screws to match the number of pre-drilled white plastic clips on the front of the cabinet.

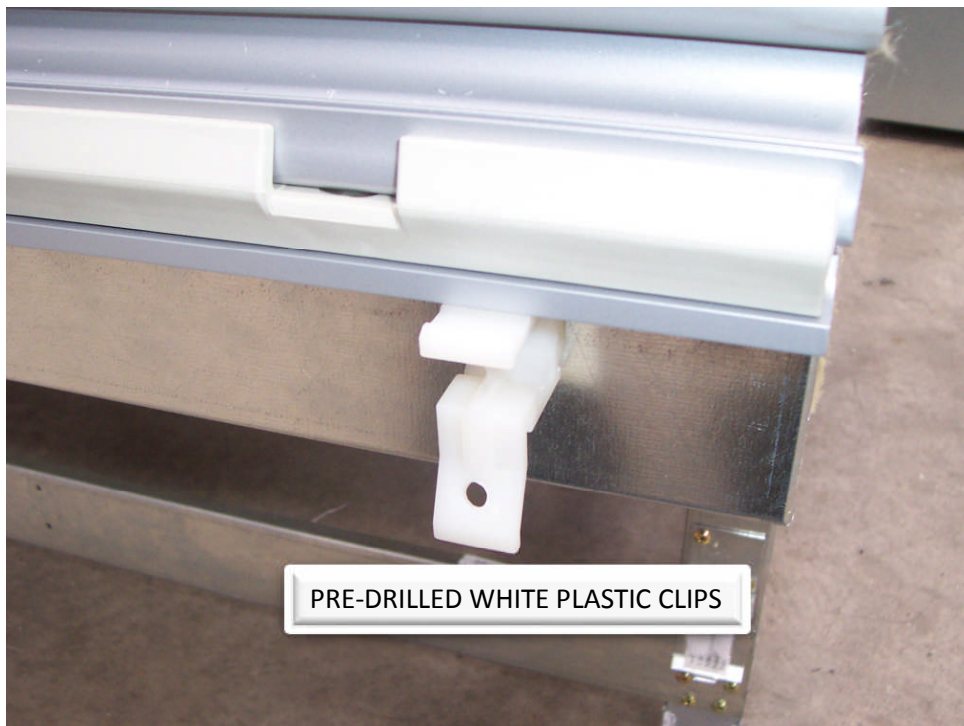



2. Before fitting the upper colour panel (painted panel that sits at 45°), fit the bumper assembly.
3. Align the bottom groove in the aluminium extrusion with the bottom tag on the plastic clips.

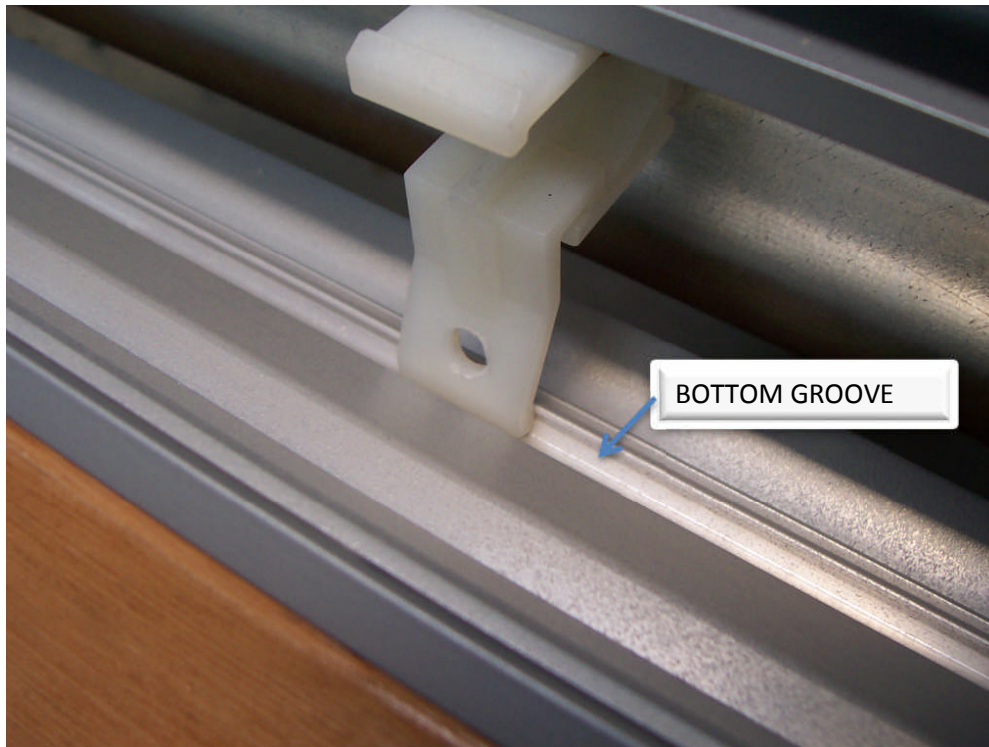

4. Push the top of the bumper assembly on to the plastic clips.



**NOTE: If some bottom tags on the plastic clips do not sit in the extrusion correctly they can be pushed into place once the assembly has been fitted. This can be done using your fingers from below the assembly.**

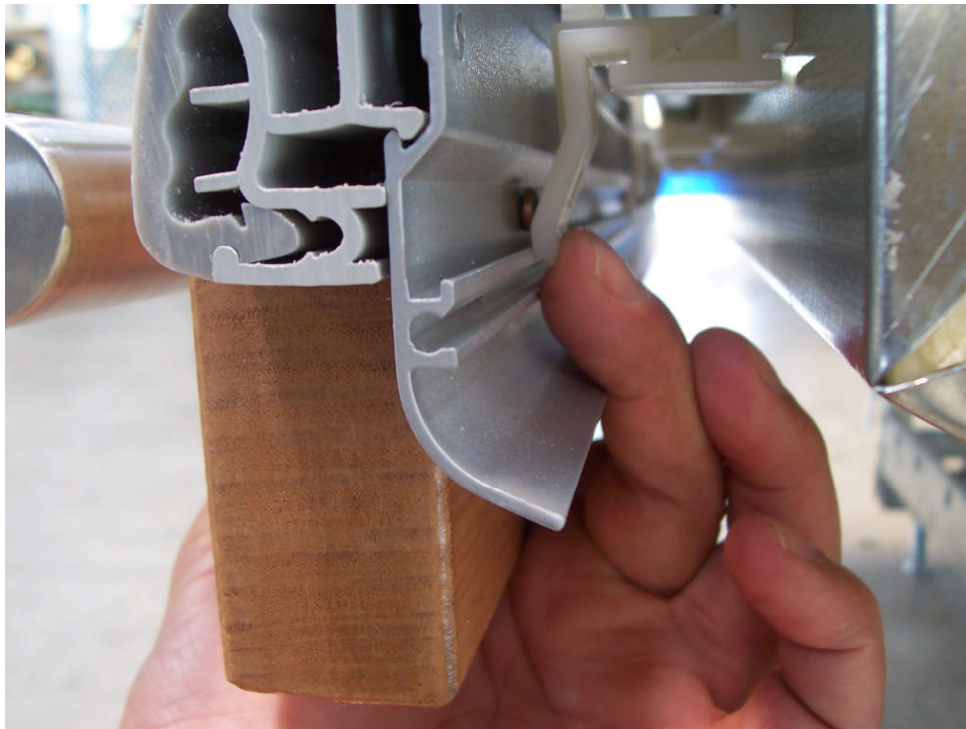

5. Pre-drill the bumper assembly aluminium extrusion at every white plastic bumper clip with a 4.5mm drill bit, taking care not to drill through the front bumper rubber (see insert picture for drilling depth)

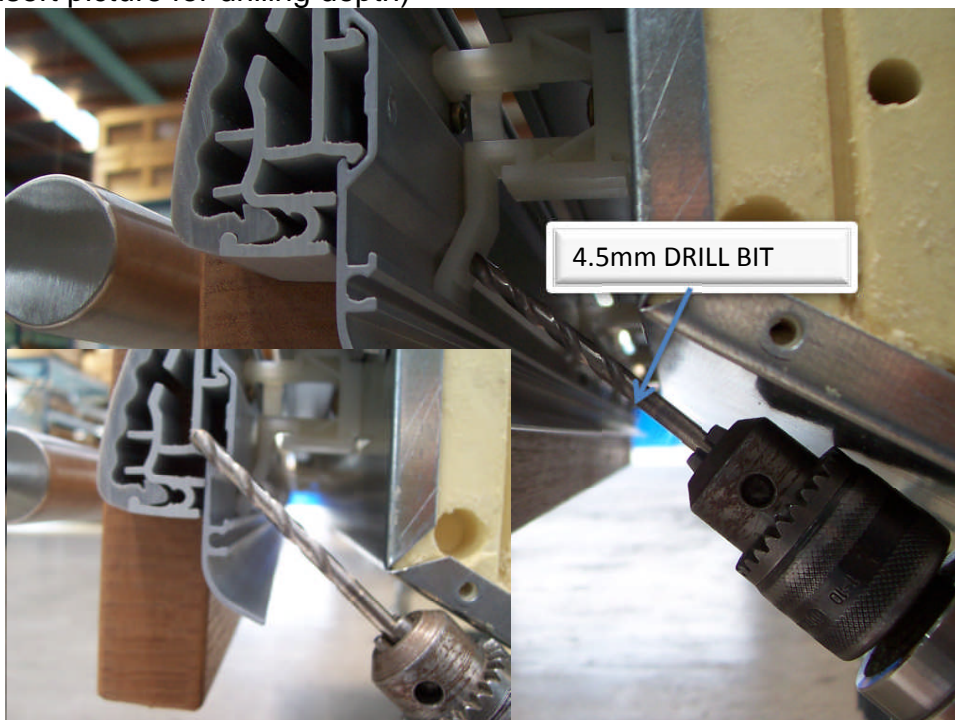



6. Fit hex head securing screws to every white plastic bumper clip. It is advised that the screws provided are used to ensure secure fixing

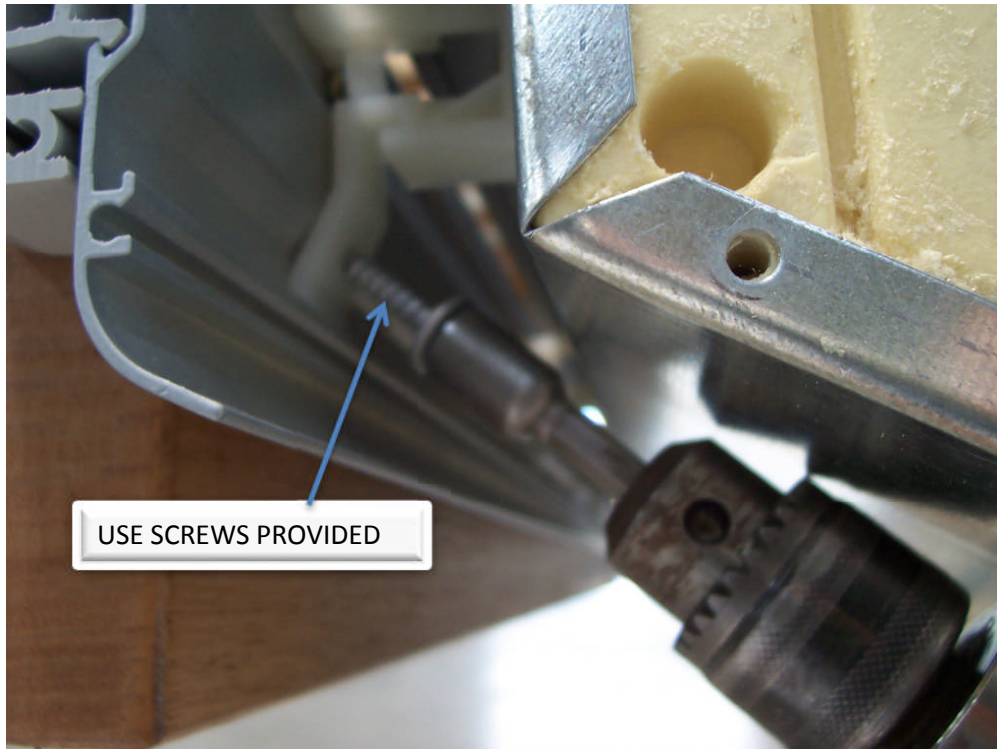

7. Front colour panels can now be fitted



## ADJUSTING FRONT GLASS (VLL726E ONLY)

**IMPORTANT! Ensure the power to the cabinet has been disconnected before commencing work.**

Adjusting the rear posts will require the following tools:

- Cross head screwdriver (Philips) PH2
- Square drive screw driver S2
- Star drive keys
- Allen keys
- Adjustable wrench

Adjusting the rear posts.

1. Remove the screws on the rear work top. Taking care not to damage the trace heating wires, unhook the front of the work top and roll the back forward to lay the work top against the canopy arms.



Screws to remove are along the rear edge and into each arm at the front

2. Loosen the grub screw on the foot of the rear post.

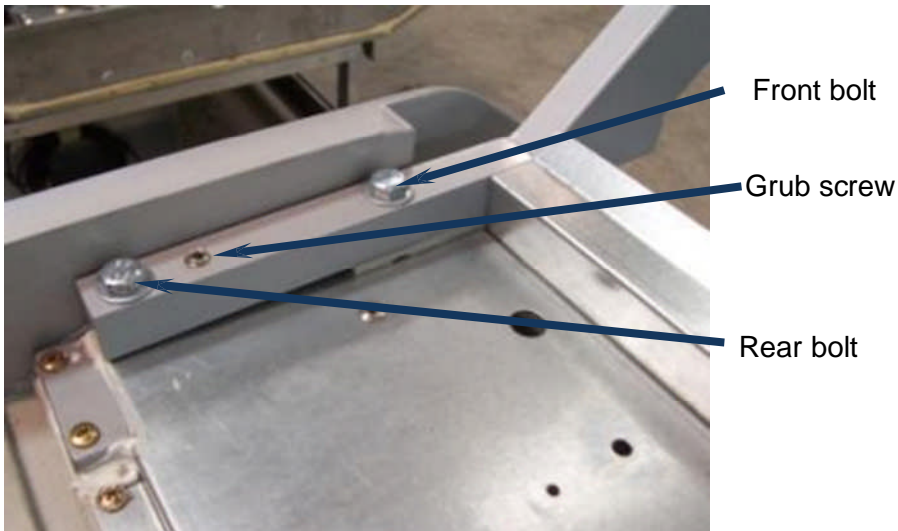

3. Adjust the post by loosening or tightening the rear bolt. This will tilt the post forward or backwards. You may need to slightly loosen the front bolt. You will need to adjust all the posts on a cabinet.
4. When the posts are aligned with that of the adjacent cabinet retighten the grub screw on the foot of the rear post.

#### Adjusting the glass

1. The glass can be moved laterally to even out the gaps between each piece of glass.
2. Lift the glass to the fully open position
3. Loosen the grub screw on the locking plates at each hinge.

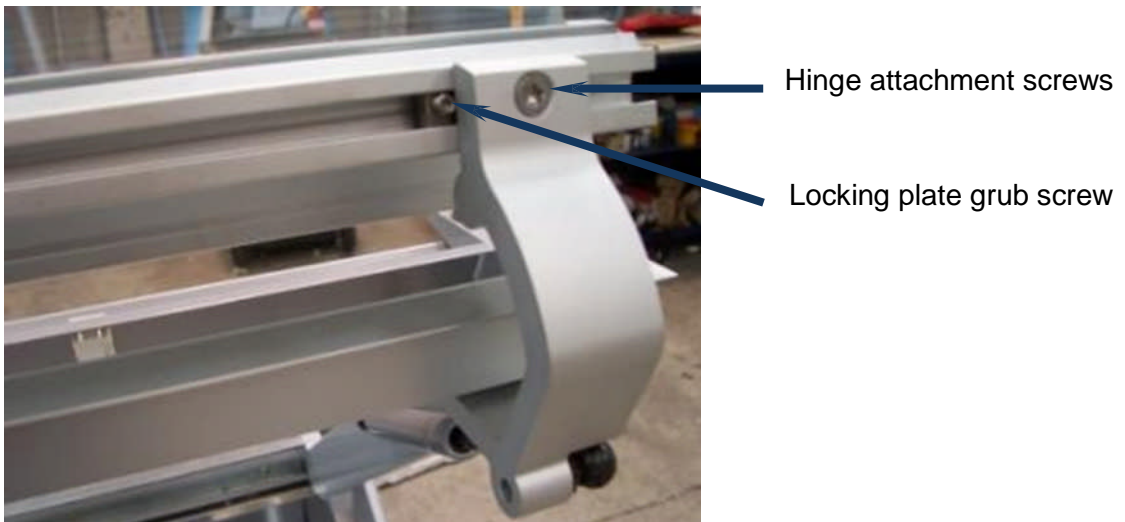

4. Loosen the hinge attachment screws on each hinge. This will allow the glass clamp to be moved.
5. Tighten the hinge attachment screws on the hinges before lowering the glass to check the new position.
6. When the new position is attained check again that the hinge attachment screws are tight. If they are not the glass will sit at different heights and the glass clamp extrusion could be damaged.
7. Tighten the locking plate grub screws.

## **ELECTRICAL INSTALLATIONS**

The electrical installation shall:

- Meet existing regulations and safety codes,
- Have an electrical supply to the cabinet that is independent of other supplies,
- Be individually isolated,

There is a wiring diagram in the electric box of each cabinet.

If you require a replacement wiring diagram, please contact McAlpine Hussmann. Please supply cabinet serial number with the request.

## **DRAIN INSTALLATIONS**

Points to be aware of for cabinet drain installation:

- The cabinet should be correctly leveled,
- Water traps are factory fitted to the case,
- The installer should ensure that the drain then slopes to the drainage point,
- Drains may need insulating to prevent condensation dripping onto the floor,

## **PRE-START CHECK LIST**

It is suggested that the following items be included but not limited to any pre-start check of this cabinet.

- All electrical connections are secure and electrical tests completed.
- Refrigeration system has been pressure tested.
- Drain traps have been primed with water to seal and drain screens are fitted where provided.
- Any loose material created during installation has been cleaned from the cabinet. Pay particular attention to filings that may be caught under the evaporator and fan panel seal. These could cause rust spots and pitting that could permanently damage the stainless steel.
- All electrical, refrigeration and sensor penetrations have been sealed inside and outside the cabinet. Including any penetrations through baffles or other internal panels
- Fan panels seal correctly



# CABINET OPERATION

## LOADING LIMITS

VLL726E – VLL726BL – VSS726E

These refrigerated display cabinets are not designed to cool down perishable food products but to maintain them at the temperature which they are introduced to the cabinet. For non-meat product this should be between -1°C and +5°C.

These cabinets have a load limit of 100mm above the storage surface. Product shall be kept at least 20mm below the bottom of the air delivery vents. Food products stored within the load limits are properly refrigerated. Food products stored outside the load limits may not be properly refrigerated, and disturb the airflow with the result that cabinet performance is compromised and food products may be damaged.

**VLL726E**

**VLL726BL**

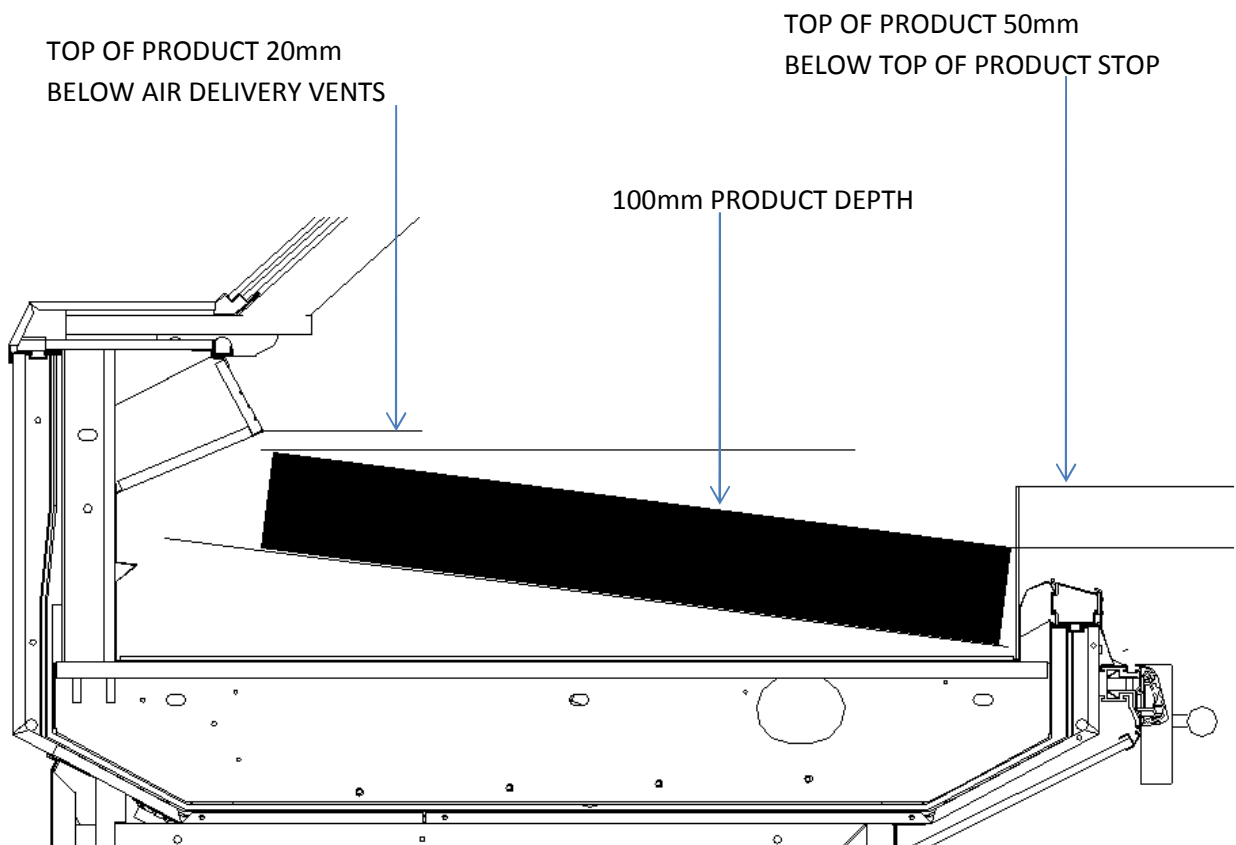

VSS726E

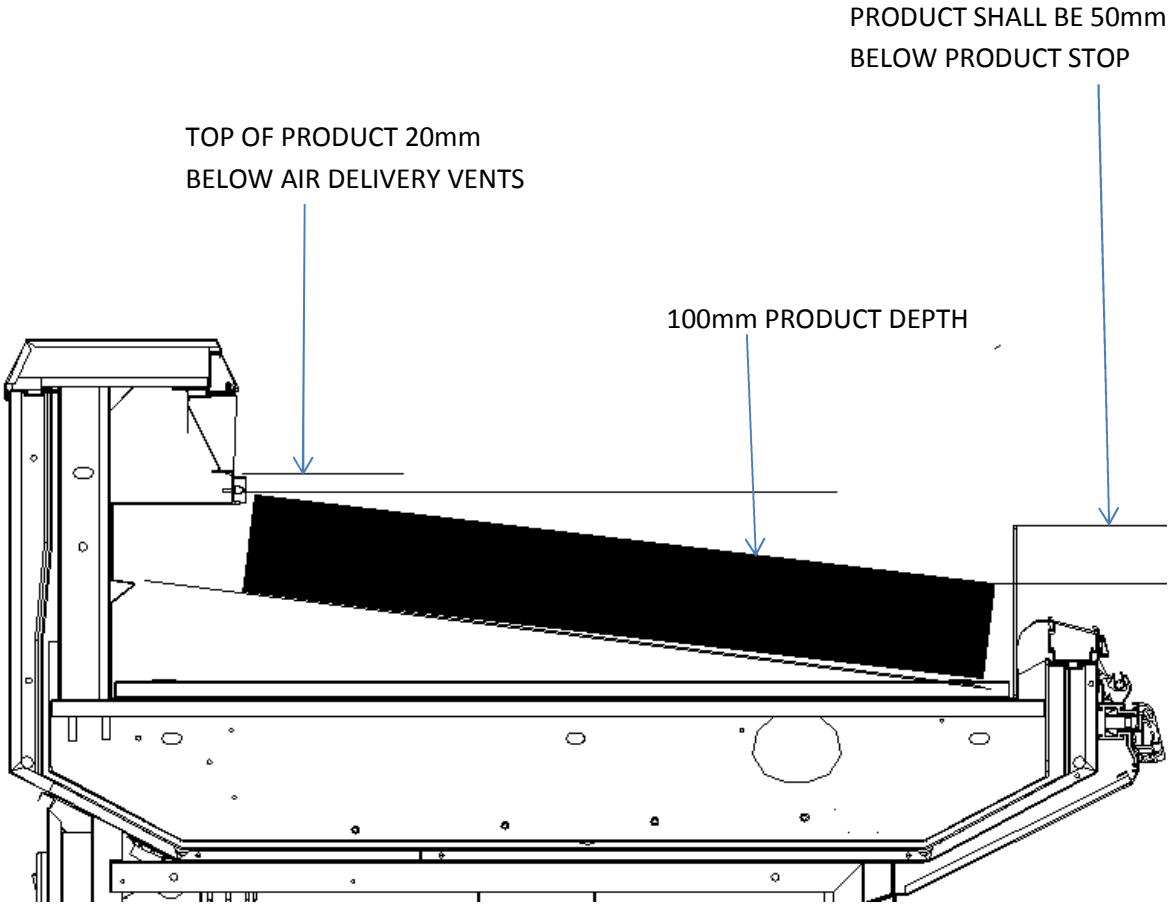

VSS726E cabinets are available with curved or straight front glass

VLL727BL

This refrigerated display cabinet is not designed to cool down perishable food products but to maintain the temperature at which they are introduced to the cabinet. Ice should not be stacked more than 20mm above the Ice tray. Product should be at least 20mm below the rear air delivery vents.

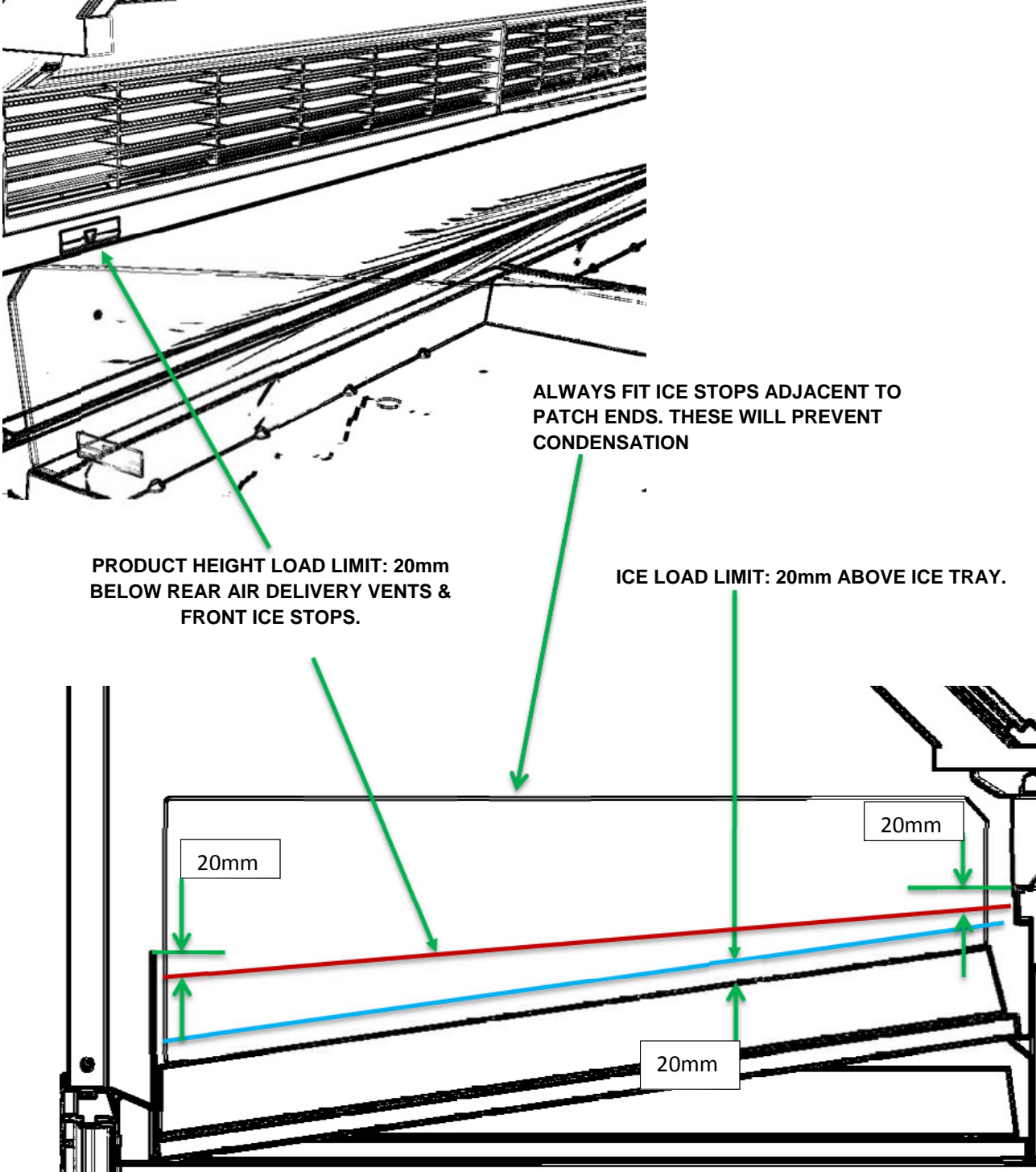

## VVS727E

This refrigerated display cabinet is not designed to cool down perishable food products but to maintain the temperature at which they are introduced to the cabinet. This cabinet has a load limit of 100mm above the shelves and the deck rack. Food products stored within the load limits are properly refrigerated. Food products stored outside the load limits may not be properly refrigerated, this may disturb the airflow with the result that cabinet performance is compromised and food products may be damaged.

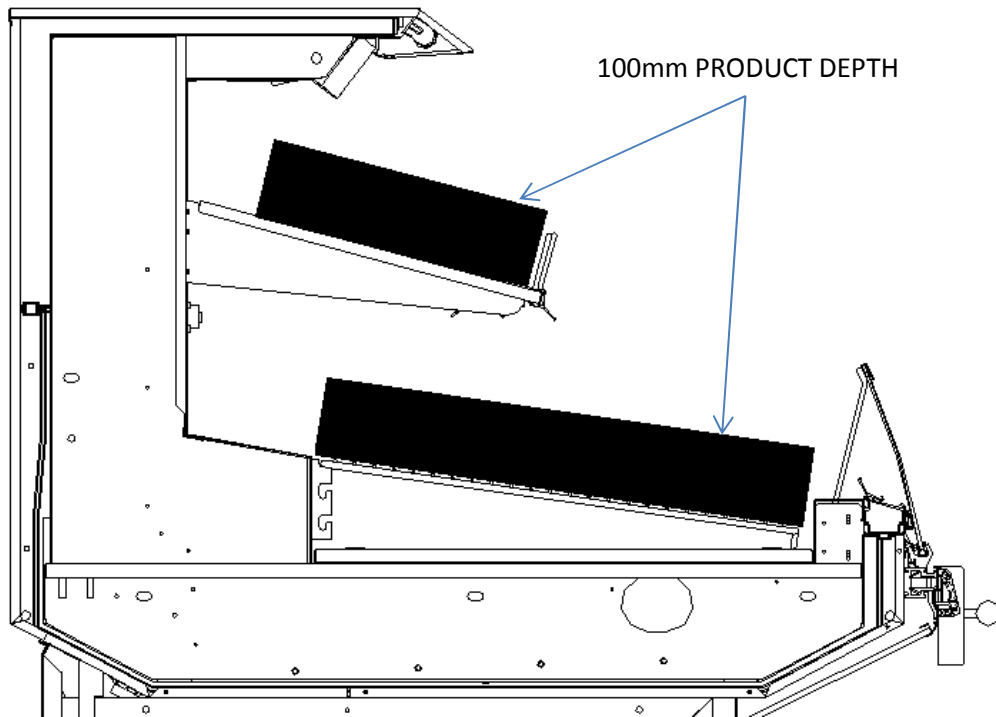

VVS727E cabinets are available with curved or straight front glass.



## **FITTINGS AND ACCESSORIES**

Only fittings and accessories supplied with the cabinet should be used. Any other additions may cause the cabinet to not work in its intended fashion.

### **VLL726E and VLL726BL fittings and accessories may include:**

- Front product stops
- Display racks
- Bag holders
- Glove dispensers
- Scale mounting frames

### **VSS726E fittings and accessories include:**

- Front product stops
- Bag holders
- Glove dispensers

### **VLL727BL fittings and accessories include:**

- Ice trays
- Front ice stops.
- Product dividers
- Bag holders
- Glove dispensers
- Scale mounting frames
- Patch end ice stops – These fit inside the ice tray adjacent to the patch end. Bank ice against them to hold in place

**It is very important that the patch end ice stops are fitted. They prevent condensation from forming on the outside of the cabinet**

### **VVS727E fittings and accessories include**

- Shelf fences, wire or perspex
- Product dividers
- Olive bar canopy kit
- Canopy light shield\*.

**The canopy light shield is a standard perspex part that is sent as a loose item to prevent transport damage. This must be fitted to protect light tubes and help with cabinet operation.**

### **The following are general examples of things to avoid:**

- The use of large merchandising signage inside the cabinet as these may disturb air flow
- Product stands that elevate product above the stated load limits
- Manufacturer supplied ice trays turned upside down to elevate product.
- **Display decorations, product and price tickets over the air return vents**

## **TEMPERATURE CHECKING**

The air delivery temperature in this case should be checked at least once a day.

- The temperature should be below 1°C.
- Checking should be done systematically and the temperature recorded

# MAINTENANCE

## CLEANING

To maximize efficiency and durability, It is suggested that your cleaning and maintenance program include a deep clean weekly and a maintenance clean daily

- Deep cleaning should include:
  - Removal of all food products.
  - Removal of all removable panels.
  - Remove all food scraps.
  - Sanitizing wash.
  - Rinsing with clean water.
- Maintenance clean should include:
  - Removal of all food products.
  - Wipe down of all exposed panels.  
**Do not pour water or cleaning solutions into the cabinet**
  - Inspect for spills that may require deeper cleaning.

**NOTE: if a liquid spill should occur, the spill should be cleaned as soon as practicable. Liquids in pickled product can be particularly acetic, and if left will risk damage to some components in the cabinet. Fresh water can be used to dilute the liquid spill until the first opportunity for a deep clean to be carried out.**

Cleaning instructions can be found on the rear of case.

**IMPORTANT! Always isolate the cabinet from the mains power supply before deep cleaning.**

For cleaning use:                      Warm water  
    Water based solutions  
    Soft cloths

Do not use:                                Abrasive products  
    Solvent based products

- The front glass can be removed for cleaning (VSS726E, VVS727E).
- Keep water away from electrical components.
- Do not flood the tub area (below the deck display area) as electrical components and penetration seals may be compromised causing damage and water leaks
- Check drain traps are clear of obstructions.
  - VLL727BL drains are at the rear of the tub area.
  - VSS726E, VLL726E, VLL726BL drains are under the cover behind the evaporator.
  - VVS727E drains are under the Evaporator fan panel. The rear deck rack support panel will have to be removed first to allow the fan panel to be lifted. It is important to replace the fan panel so it seals to the tub.

Stainless steel is used inside the cabinet to give a strong corrosion resistant finish that maximizes the cabinets service life.

**It is not rustproof**, particularly in the harsh environment of Food Display cabinets. Chlorine and bromine, commonly used for sanitisation are highly caustic chemicals for stainless steel and heat and humidity enhance the corrosiveness of these chemicals. Regular cleaning is the best way to prevent corrosion and add to the service life for your stainless steel product. The goal of your cleaning and maintenance program should be to keep the stainless steel's protective chromium oxide layer intact. This is what prevents corrosion

## **REGULAR INSPECTION**

To ensure reliability of the cabinet and leak tightness of the refrigerant circuit, it is advisable that trained personnel carry out periodic maintenance.

It is recommended that a check be made 3 months after commissioning of the cabinet and then every 6 months.

The maintenance check should include:

- Leak testing of the cabinet refrigerant circuit,
- Ensuring no damage has occurred to any electrical components,
- Cleaning the evaporator coil,
- **Particular attention should be given to the operation of any safety devices.**
- Checking lift glass to ensure it has not moved in the glass clamp and that it operates correctly (VLL726E, VLL726BL, VLL727BL).
- Ensure front and end ice stops are in good order and being used (VLL727BL)
- Damage to cabinet components that need to be replaced to ensure proper cabinet operation.

These checks will ensure the best possible performance of the cabinet over its service life.

## **DISPOSAL OF THE CABINET**

It is encouraged that the cabinet be refurbished if practical.

If disposal is necessary, please be aware that the foam-insulated panels incorporate cyclo-pentane as the blowing agent and will require the cabinet to be disposed of in accordance with local authority guidelines.

## **REPLACEMENT PARTS**

All parts that may fail during the life of the cabinet are available from McAlpine Hussmann.

**When ordering replacement parts please quote the serial number of the cabinet to ensure correct replacement.**



# CABINET SECTIONAL VIEW

- VLL726E

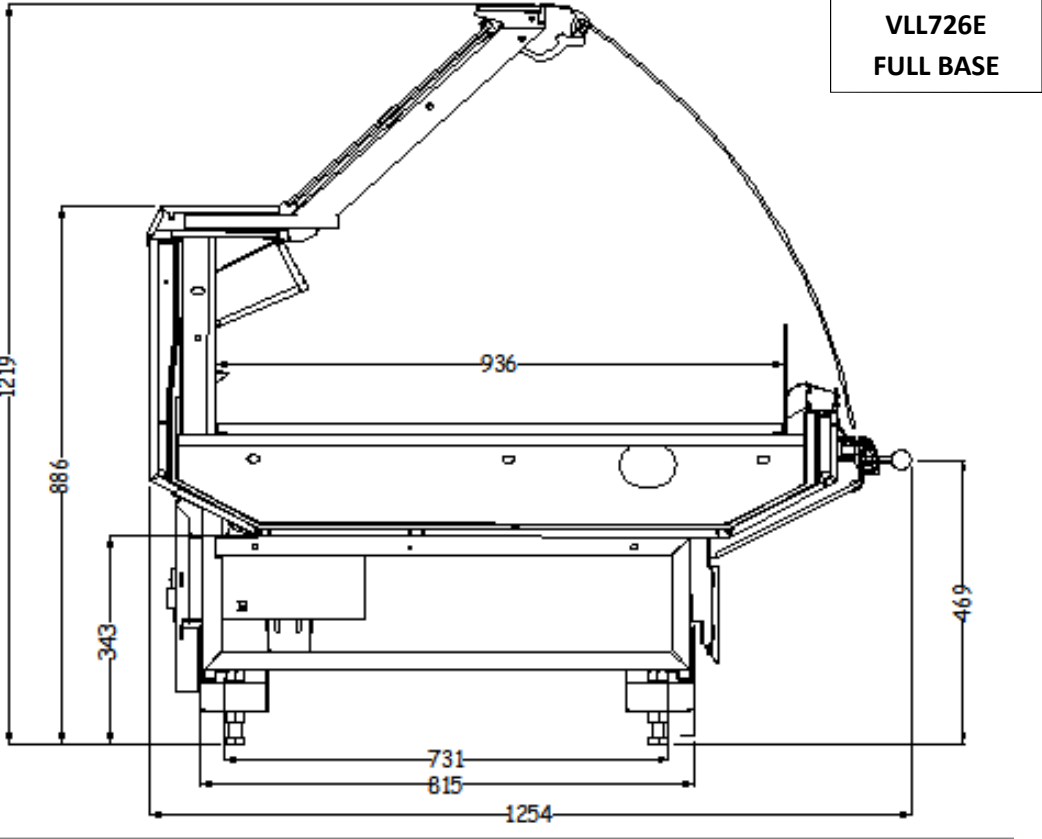
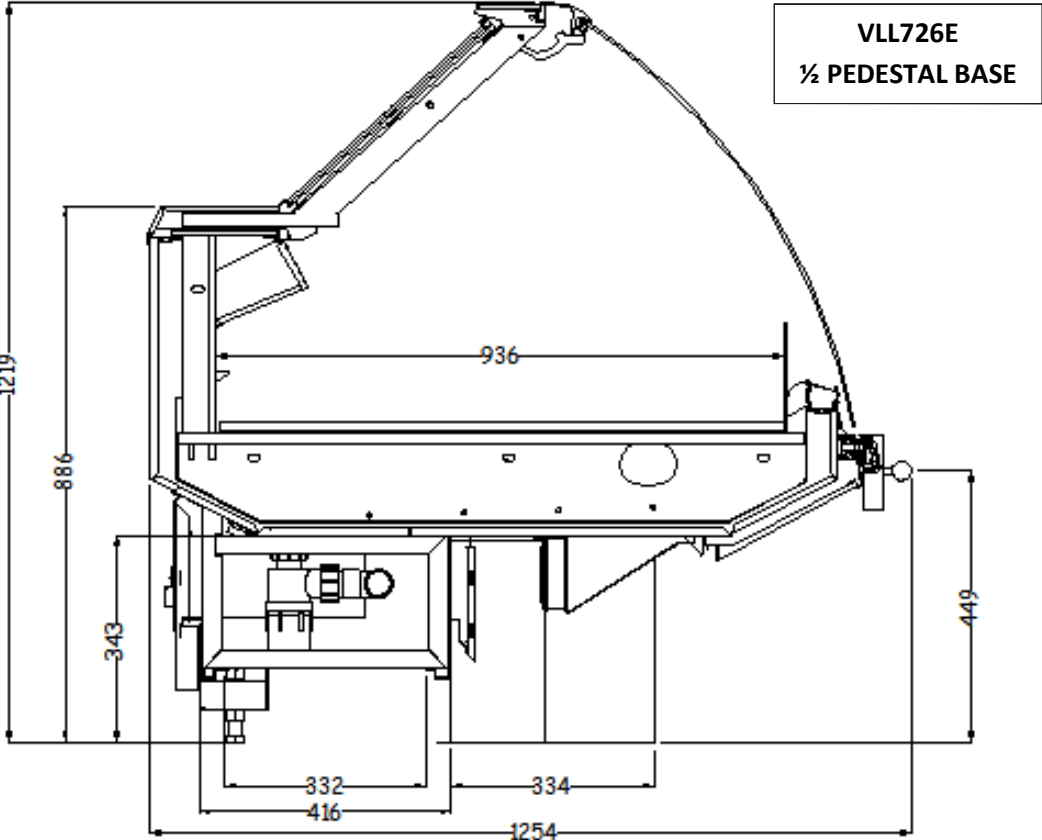

- VLL726BL

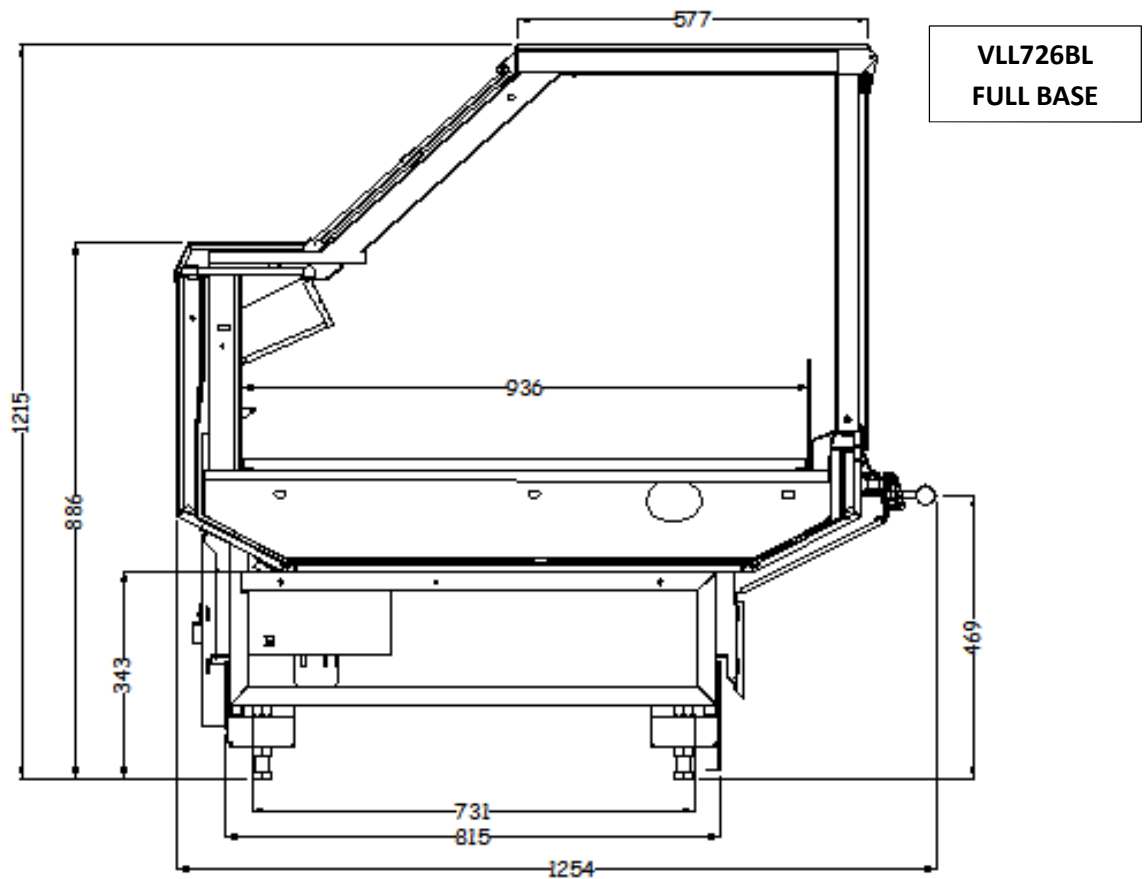
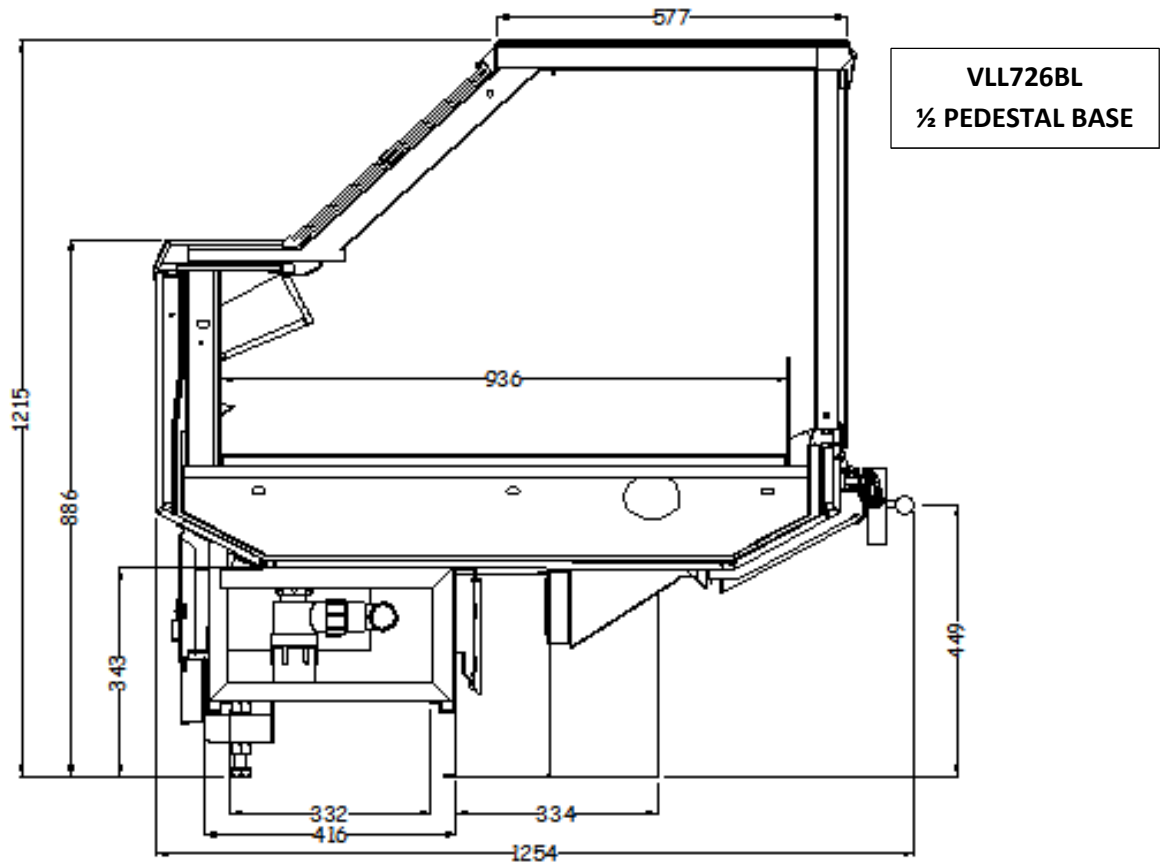

- VSS726E

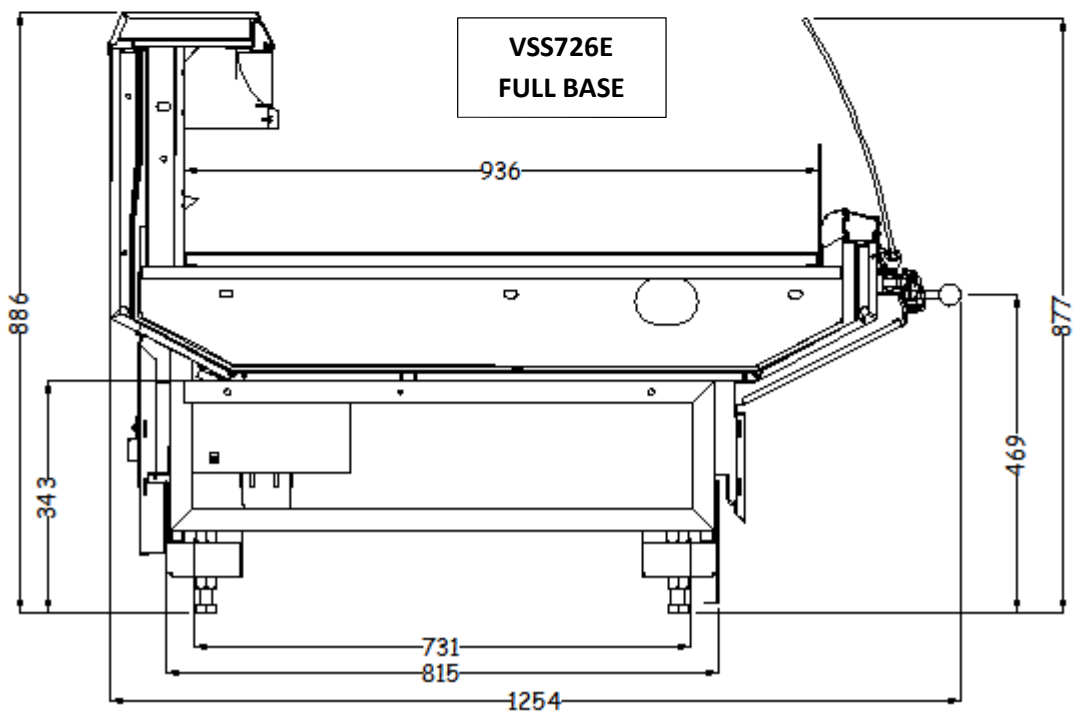
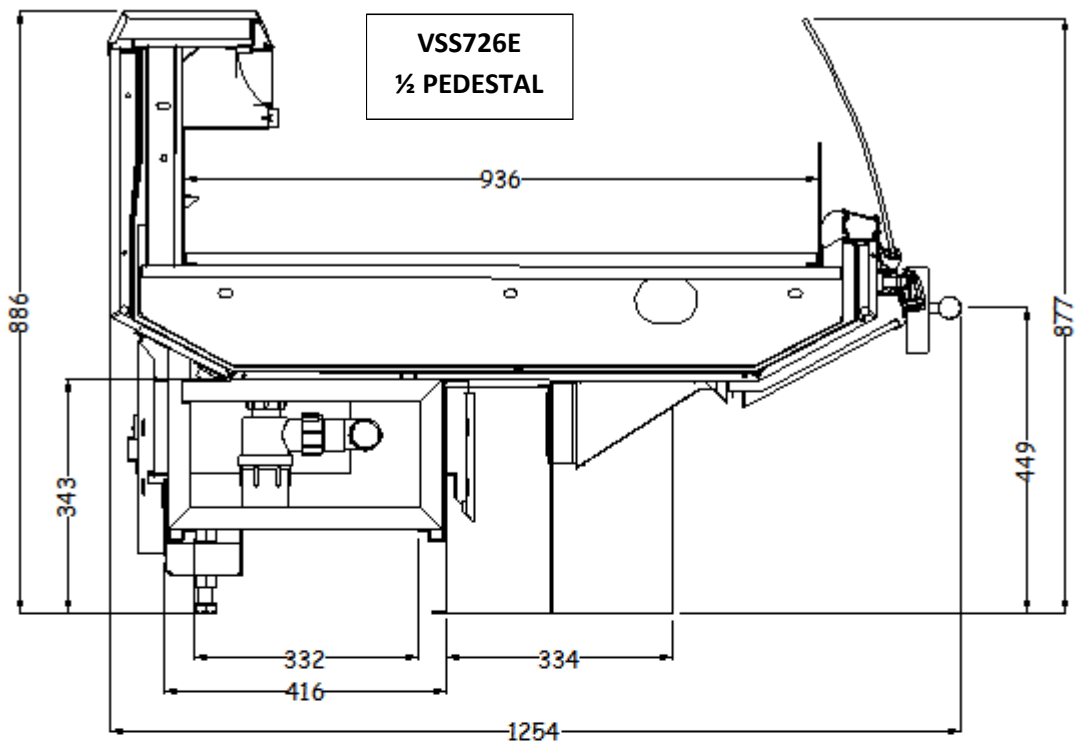

VSS726E cabinets are available with curved or straight front glass.

Curved glass cabinet VSS726E  
Straight glass cabinet VSS726B

- VVS727E

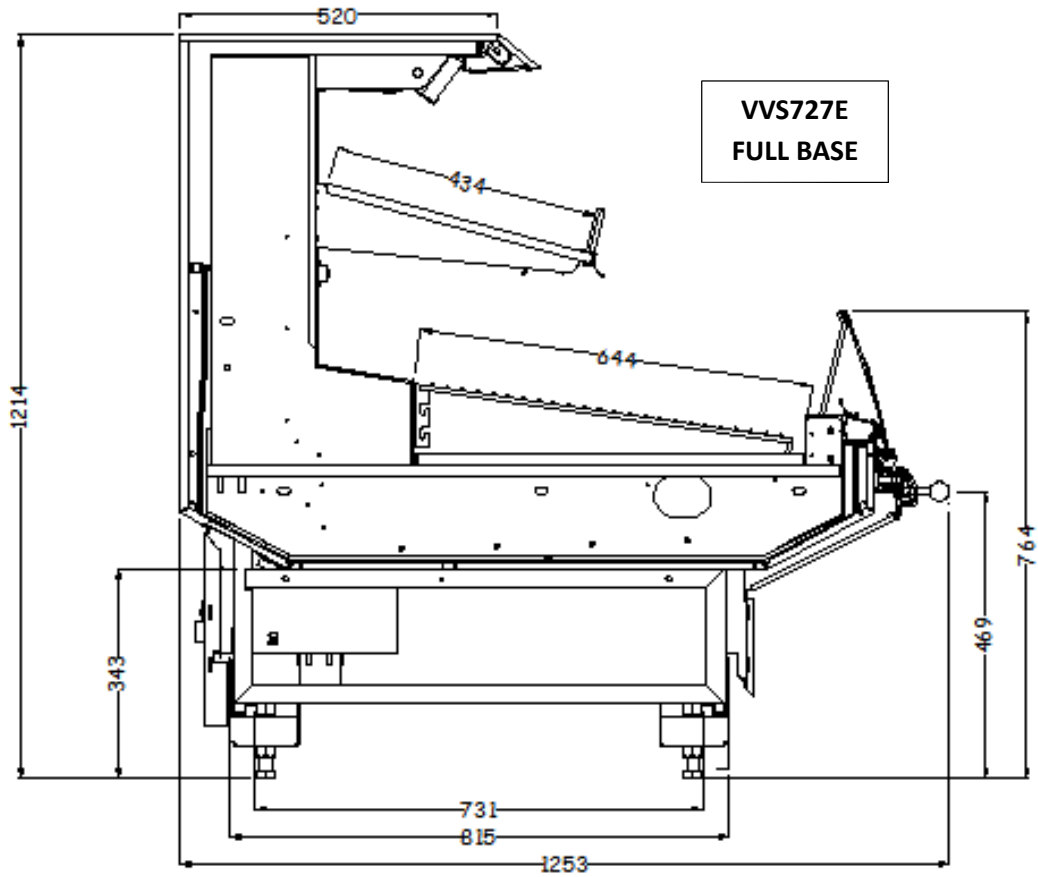
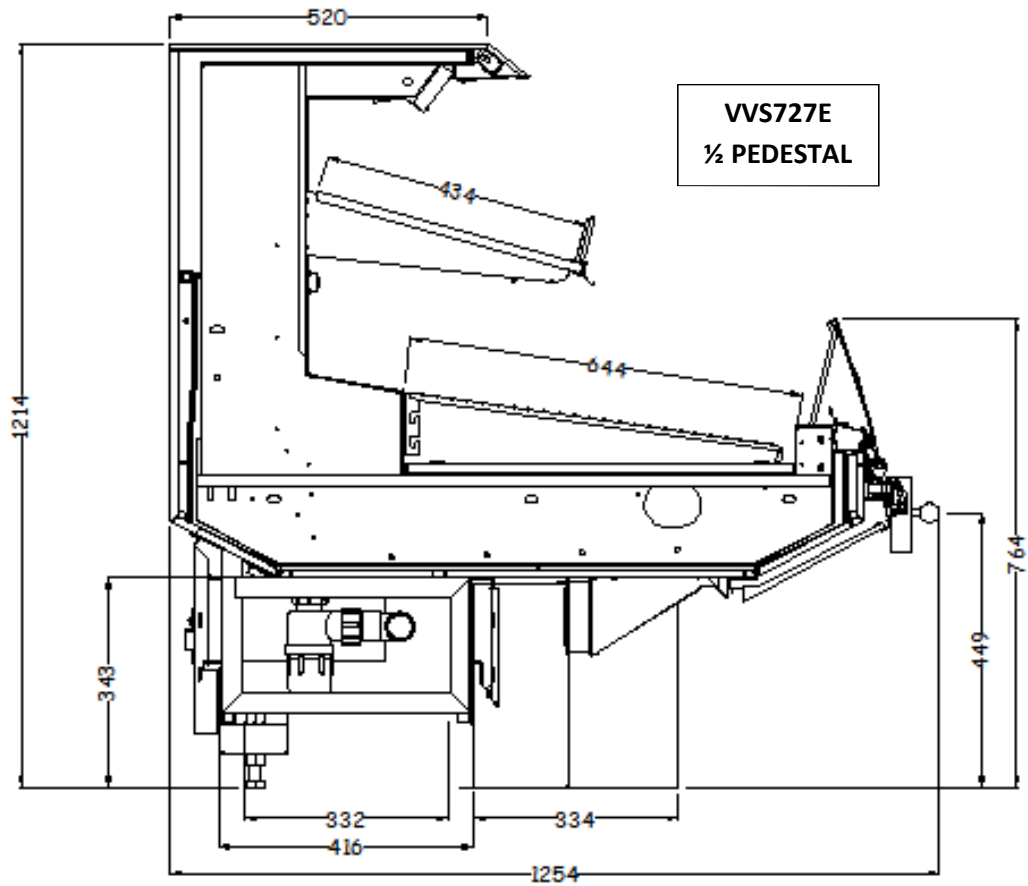

VVS726E cabinets are available with curved or straight front glass.

Curved glass cabinet VVS727E  
Straight glass cabinet VVS727B

- VLL727BL

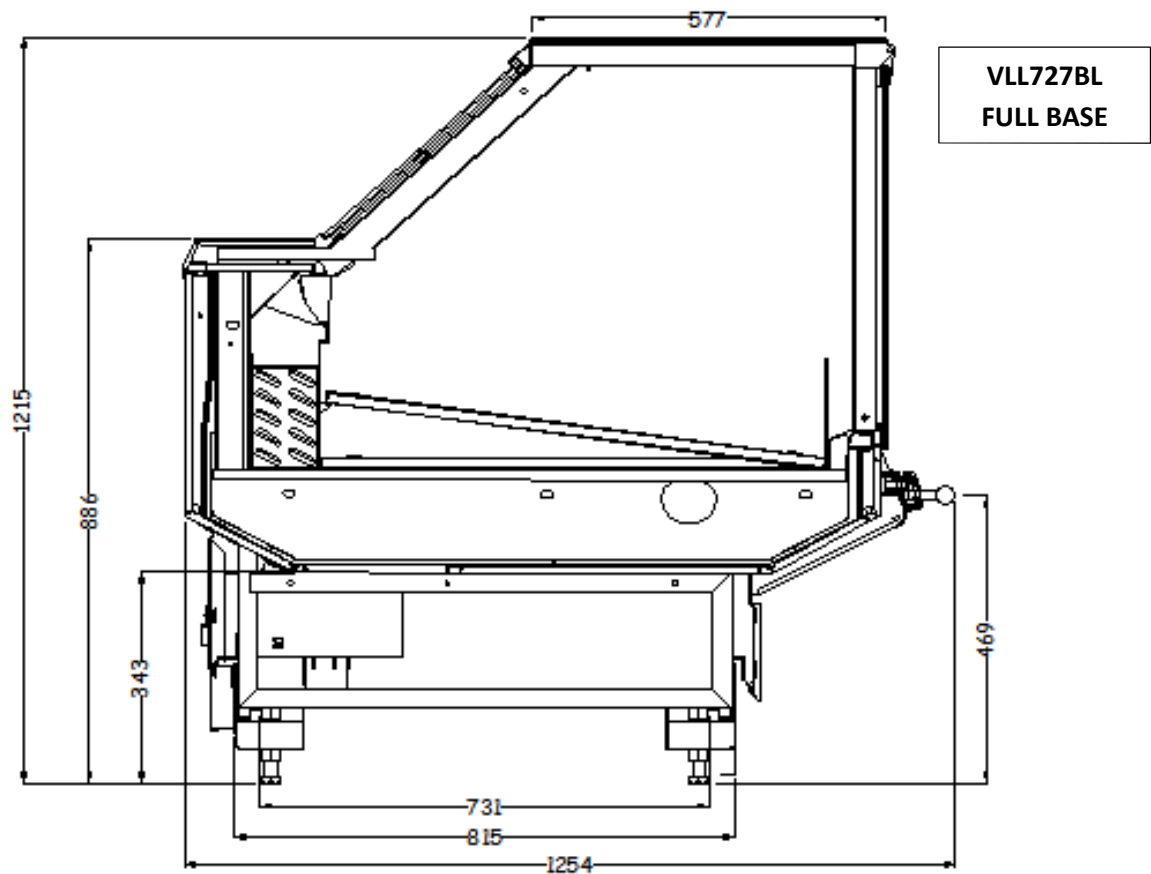
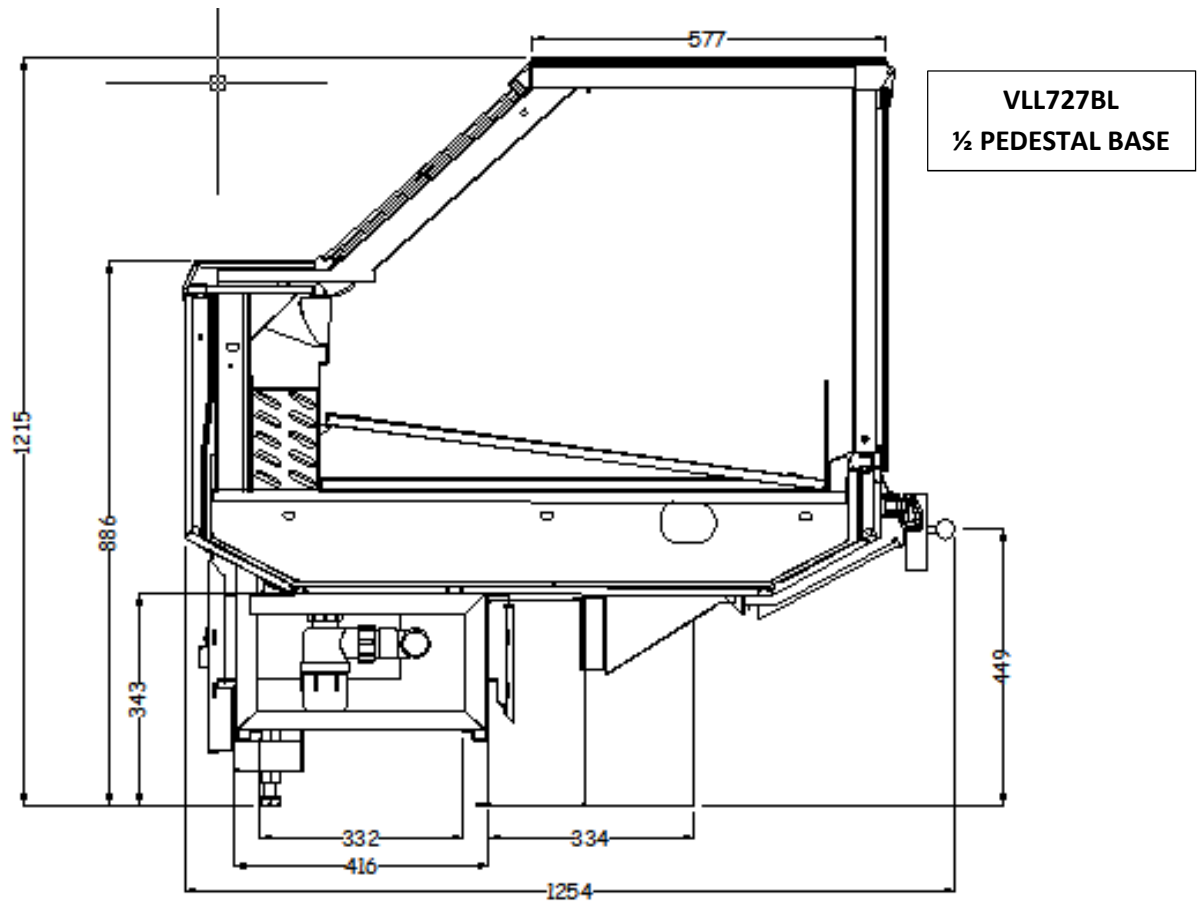

## CABINET JOINING DIAGRAMS

- VLL726E (VLL726BL and VLL727BL USE THE SAME FIXING POINTS)

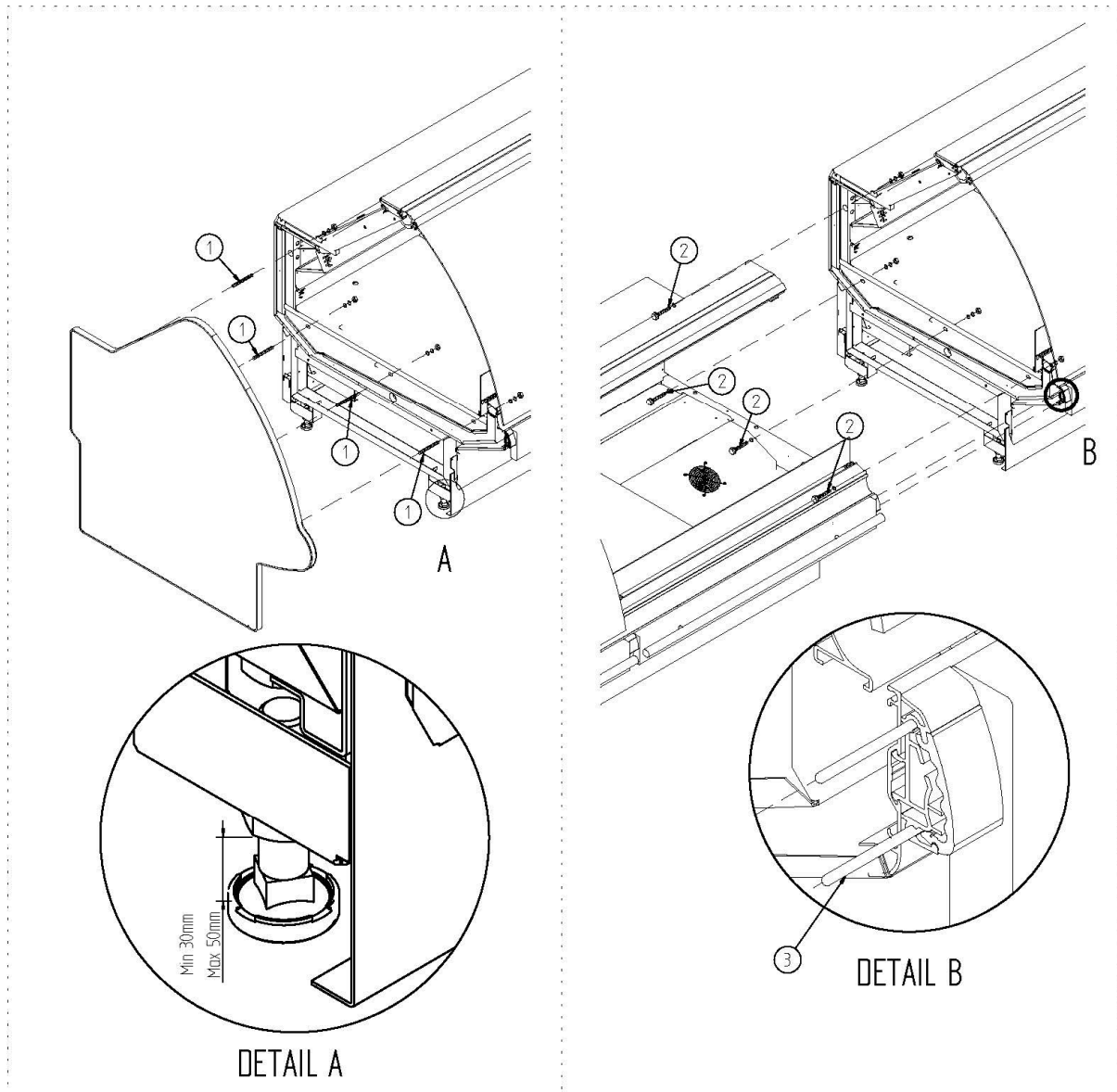

### NOTES :

- LEVEL THE CABINETS, BOTH ALONG THE LENGTH AND ACROSS THE CABINET. USE THE ADJUSTMENT BOLTS TO ACHIEVE THIS. ALL ADJUSTMENT BOLTS MUST BE USED TO SUPPORT THE CABINET.
- ENSURE THAT THE CABINET JOIN HAS BEEN ADEQUATELY SEALED WITH SNB BEFORE CABINETS ARE PUSHED TOGETHER.
- ENDS AND CORNER CABINETS JOIN USING THE SAME FIXING POINTS AND METHODS AS STANDARD CABINETS.
- WHEN JOINS AND ENDS HAVE BEEN CORRECTLY ALIGNED AND TIGHTENED, USE RTV SILICONE TO COMPLETE THE SEAL.

3	1H02266001	ROD OF UNION Ø4x40
	A340110000	KOXKA UNIT CASES PLANE WASHE Ø8
+	A330013000	HEXAD NUT M8GB6170-86
2+	1H28780001	HEXAD BOLT M8x80 GB5783-86
1+	3555406001	THREADED ROD M8x60
NO.	PART NUMBER	SPECIFICATIONS



• VSS726E

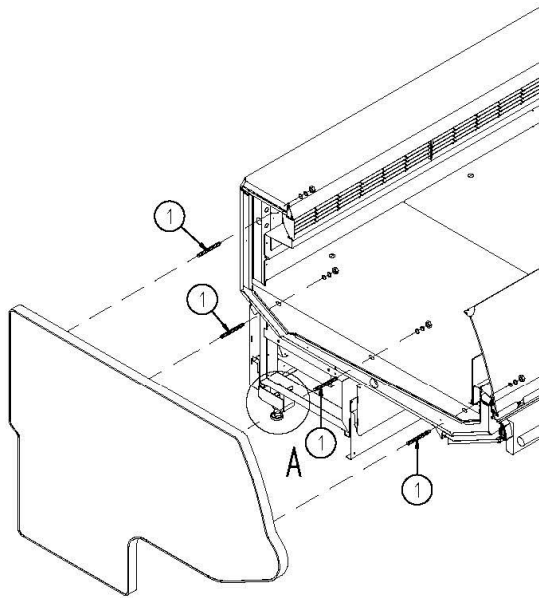

DETAIL A

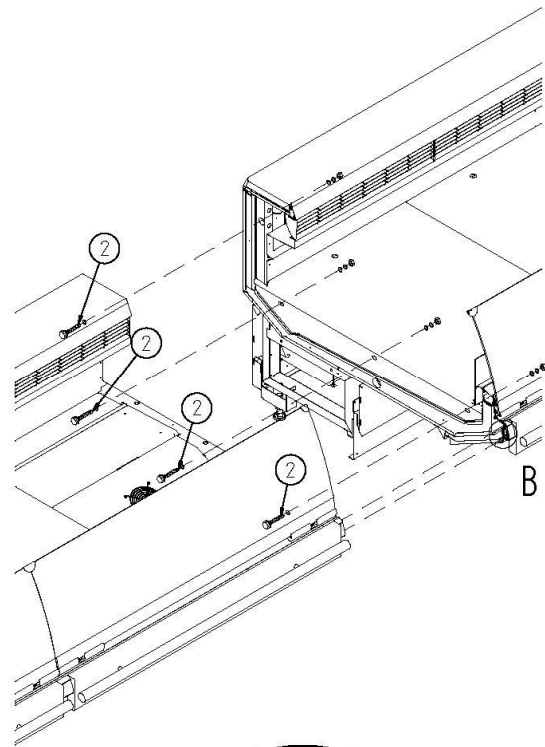

DETAIL B

NOTES :

- LEVEL THE CABINETS, BOTH ALONG THE LENGTH AND ACROSS THE CABINET. USE THE ADJUSTMENT BOLTS TO ACHIEVE THIS. ALL ADJUSTMENT BOLTS MUST BE USED TO SUPPORT THE CABINET.
- ENSURE THAT THE CABINET JOIN HAS BEEN ADEQUATELY SEALED WITH SNB BEFORE CABINETS ARE PUSHED TOGETHER.
- ENDS AND CORNER CABINETS JOIN USING THE SAME FIXING POINTS AND METHODS AS STANDARD CABINETS.
- WHEN JOINS AND ENDS HAVE BEEN CORRECTLY ALIGNED AND TIGHTENED, USE RTV SILICONE TO COMPLETE THE SEAL.

3	1H02266001	ROD OF UNION Ø4x40
+	A340110000	KOXKA UNIT CASES PLANE WASHE Ø8
	A330013000	HEXAD NUT M8GB6170-86
2+	1H28780001	HEXAD BOLT M8x80 GB5783-86
1+	3555406001	THREADED ROD M8x60
NO.	PART NUMBER	SPECIFICATIONS

• VVS727E

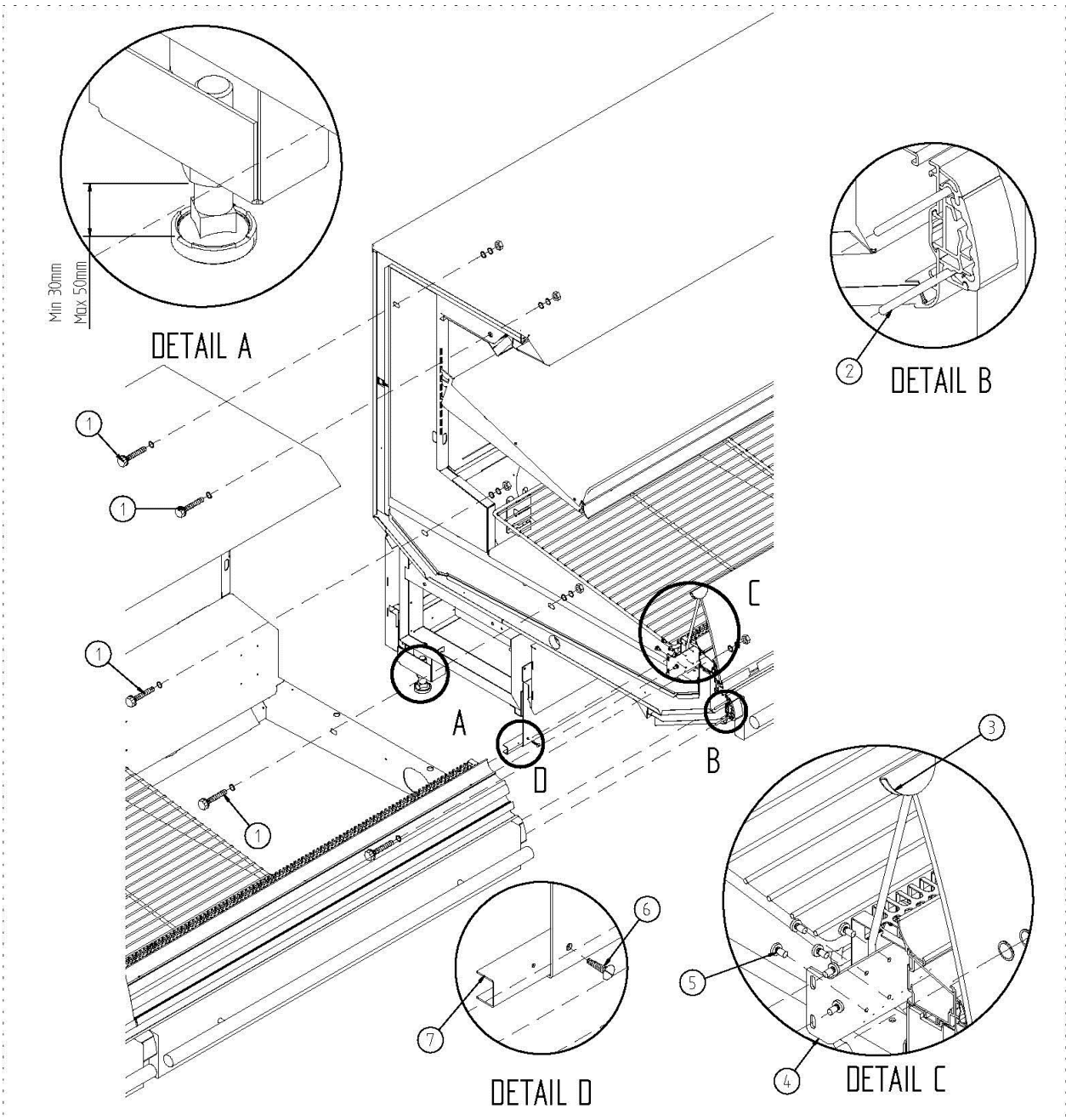

NOTES :

- LEVEL THE CABINETS, BOTH ALONG THE LENGTH AND ACROSS THE CABINET. USE THE ADJUSTMENT BOLTS TO ACHIEVE THIS. ALL ADJUSTMENT BOLTS MUST BE USED TO SUPPORT THE CABINET.

- ENSURE THAT THE CABINET JOIN HAS BEEN ADEQUATELY SEALED WITH SNB BEFORE CABINETS ARE PUSHED TOGETHER.

- ENDS AND CORNER CABINETS JOIN USING THE SAME FIXING POINTS AND METHODS AS STANDARD CABINETS.

- WHEN JOINS AND ENDS HAVE BEEN CORRECTLY ALIGNED AND TIGHTENED, USE RTV SILICONE TO COMPLETE THE SEAL.

7	1H44349001	KICKPLATE JOINTER
6	A323123000	BOLT,XSHEET SELF-DRILL ST4.2*13
5	A323133000	BOLT,XSHEET SELF-DRILL ST4.8x13
4	1H57549001	GLASS SUPPORT BASE PLATE
3	1H57556001	GLASS SUPPORT ASSEMBLY
2	1H02266001	ROD OF UNION Ø4x40
	A340110000	KOXKA UNIT CASES PLANE WASHE Ø8
+	A330013000	HEXAD NUT M8GB6170-86
1+	1H28780001	HEXAD BOLT M8x80 GB5783-86
NO.	PART NUMBER	SPECIFICATIONS

# CABINET FOOTPRINT

- VLL726E / VSS726E Frame Base**

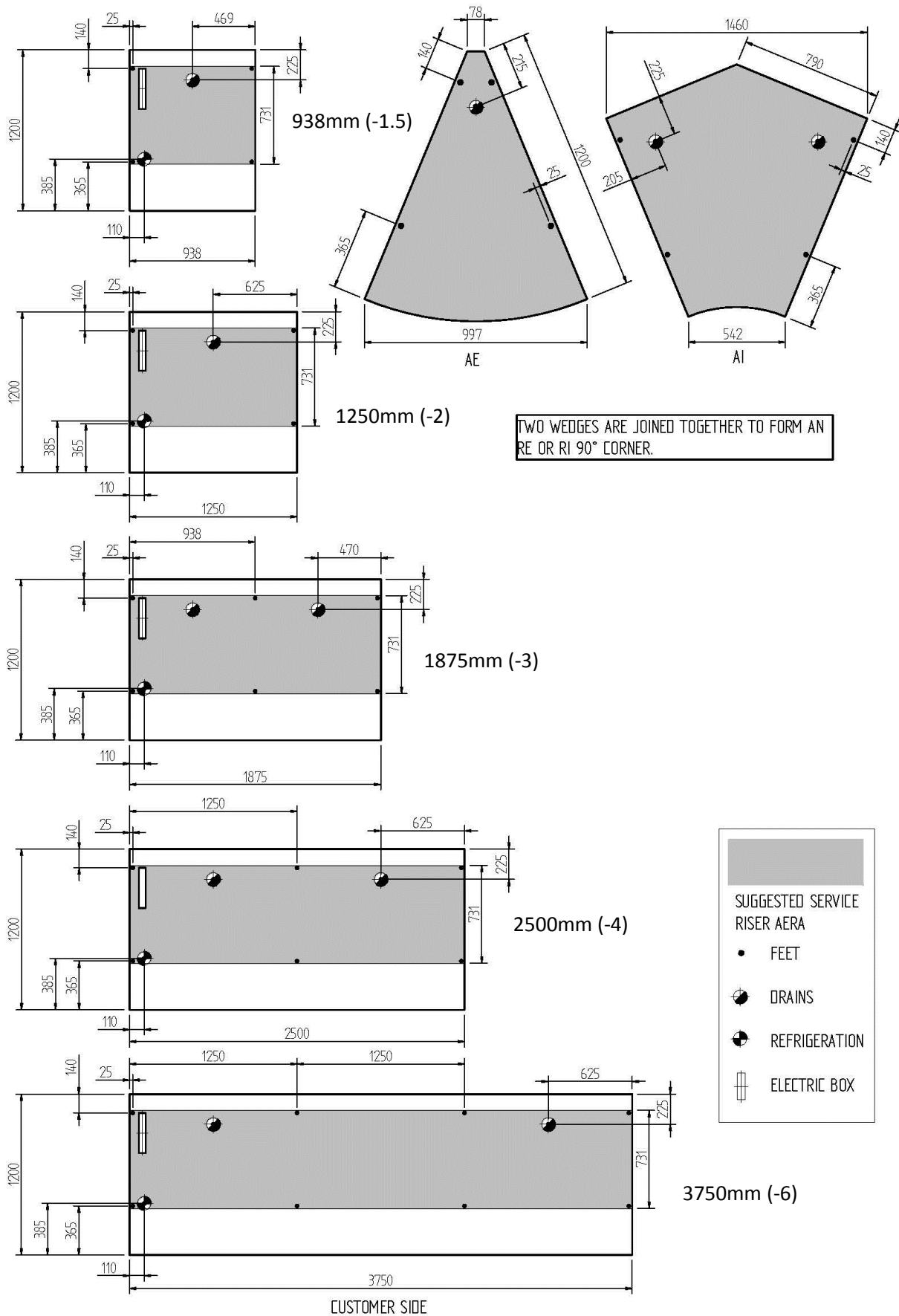

• VLL726E / VSS726E Half Pedestal Base

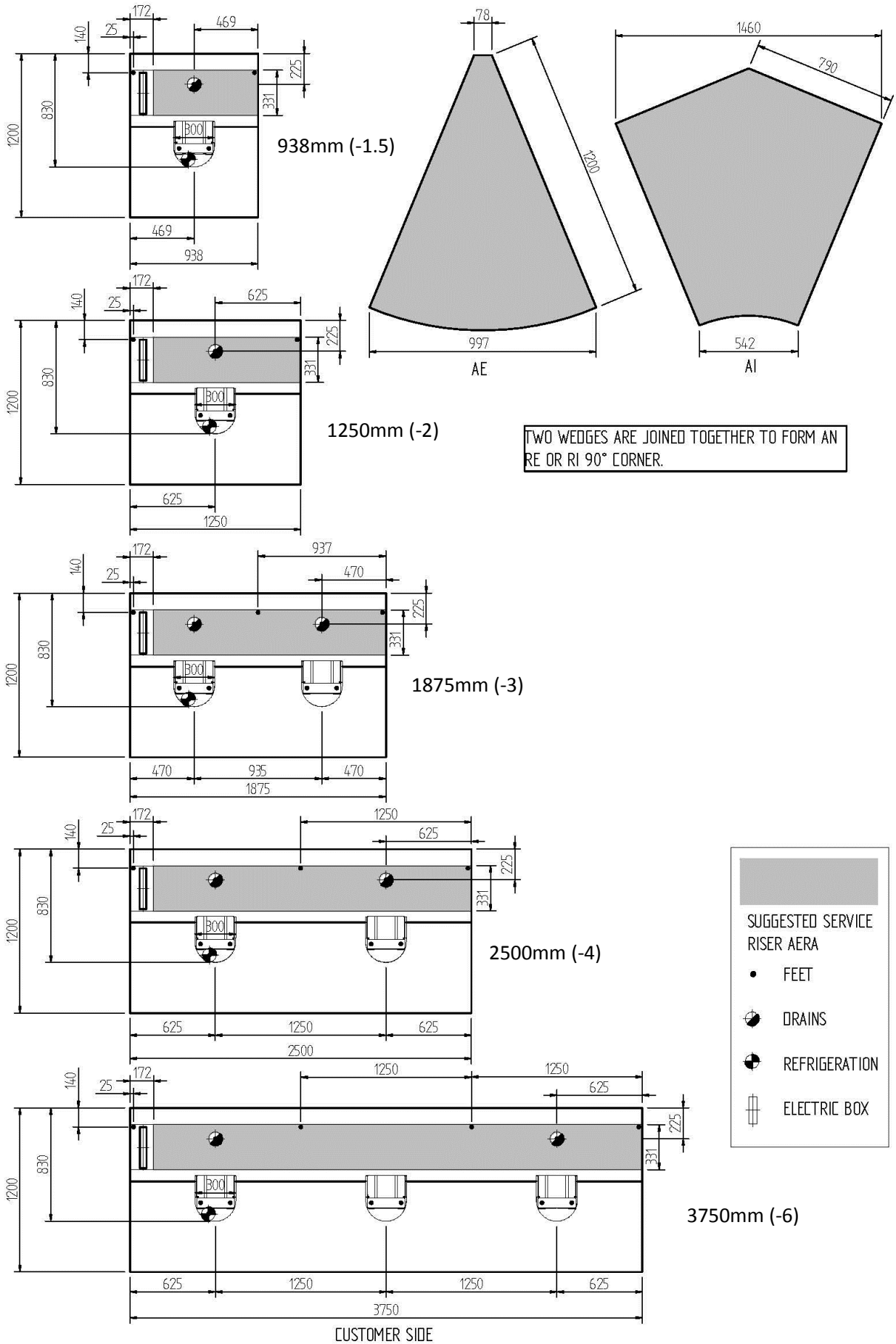



• VVS727E VLL727BL VLL726BL Full Base

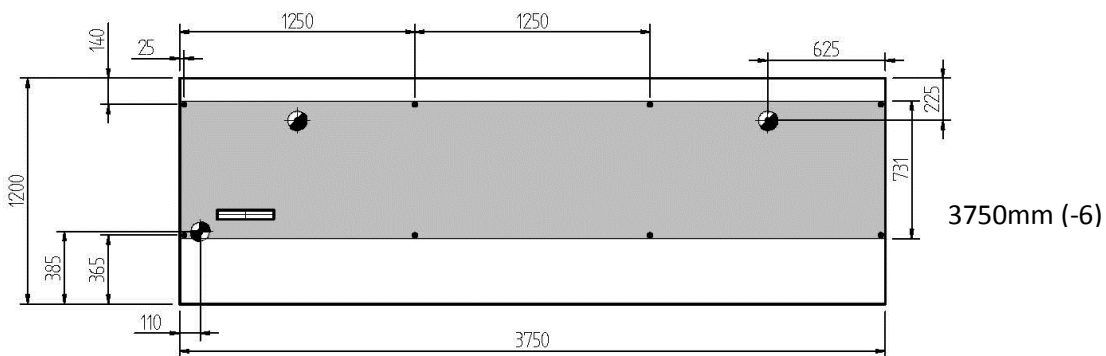
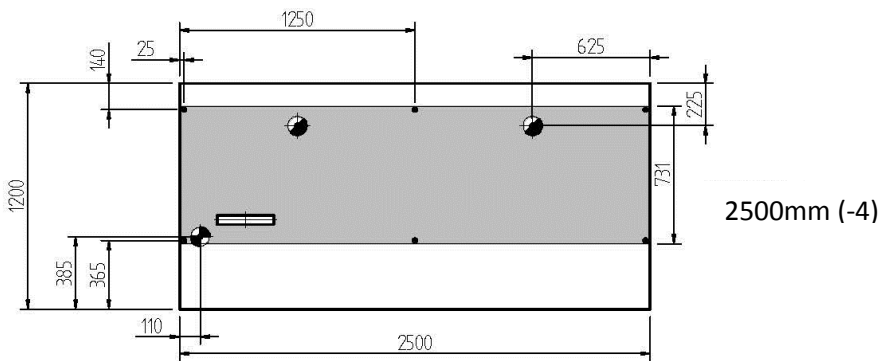
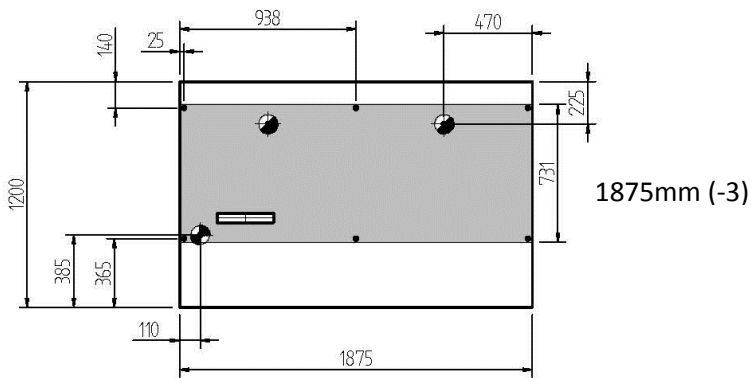
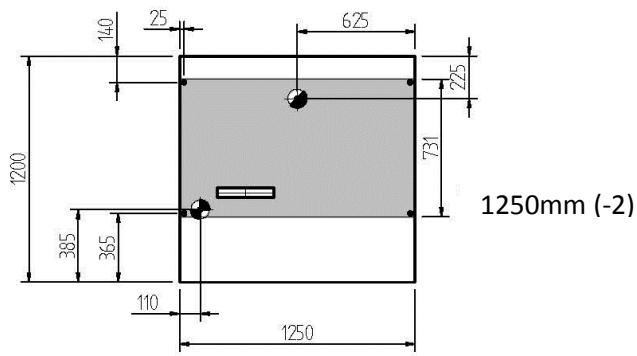

	SUGGESTED SERVICE RISER AREA
	FEET
	DRAINS
	REFRIGERATION
	ELECTRIC BOX

CUSTOMER SIDE

• VVS727E VLL727BL VLL726BL Half Pedestal Base

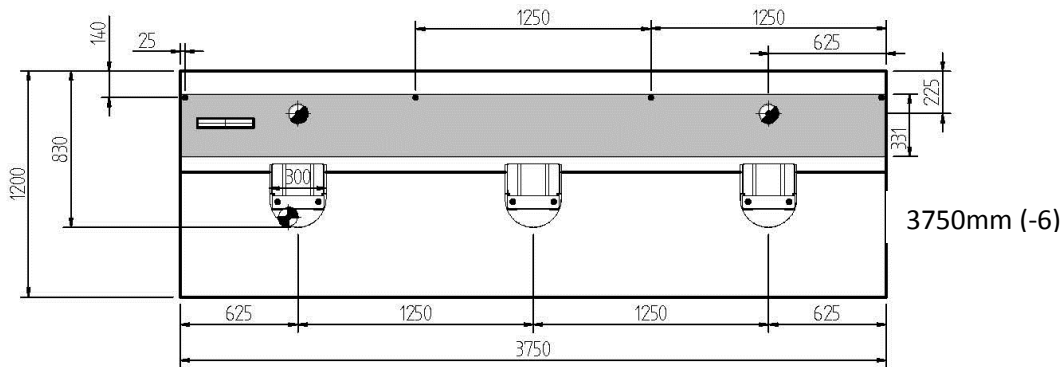
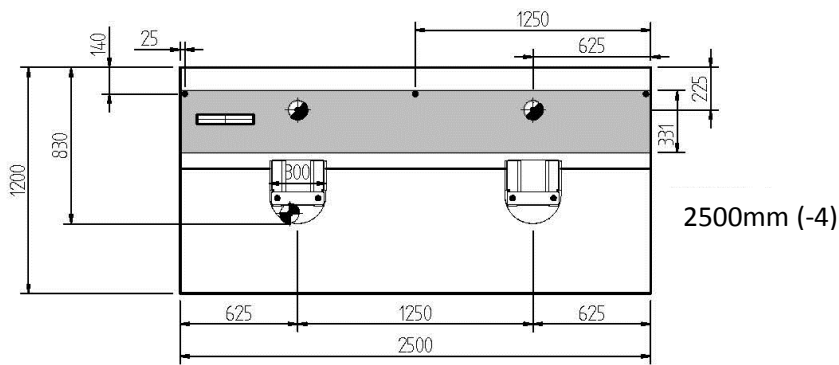
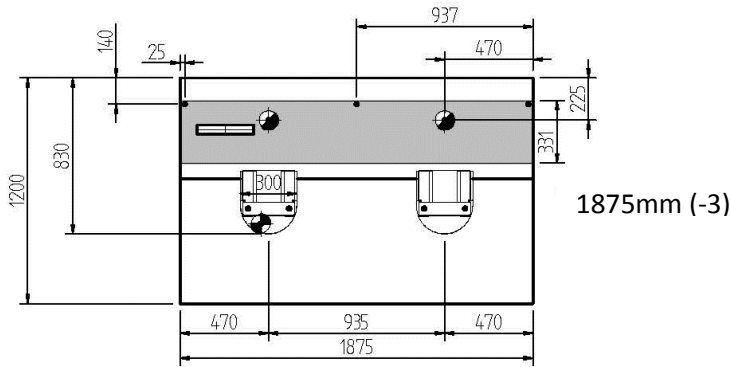
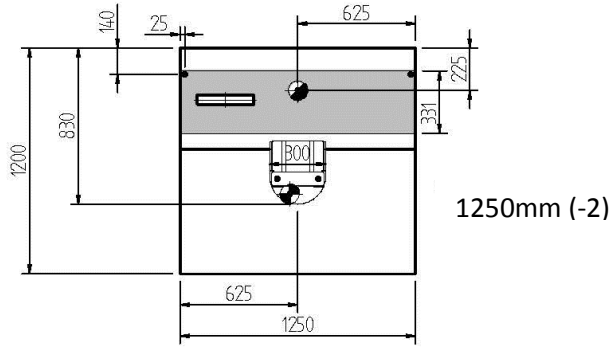

CUSTOMER SIDE

	SUGGESTED SERVICE RISER AREA
•	FEET
	DRAINS
	REFRIGERATION
	ELECTRIC BOX



## HAZARD ASSESSMENT

Hazard	Person at Risk	Potential Consequences	How Likely	Risk	Control Measures
Manual Handling while installing cabinets	Installation Technician	Strains and sprains; Bruised or crushed fingers/limbs	Likely	Moderate	Utilizes correct Manual Handling techniques. Lifting equipment should be used where possible. PPE - Gloves, Safety Boots
Installing services under cabinets	Installation Technician Service Technicians	Lacerations, Bruises	Likely	Moderate	PPE - Overalls
Electrical installation	Qualified Service Technician	Death, Burns, Electric shock	Likely	High	Electrically isolate cabinet before works
Electrical Maintenance	Qualified Service Technician	Death, Burns, Electric shock	Likely	Moderate	Electrically isolate cabinet before works
Glass Breakage	Operating Staff Installation Technician	Glass in eyes, Scratches, Fright	Unlikely	Low	Do not over stress glass or hit with objects
Glass replacement	Service Technician	Strains and sprains	Likely	Moderate	Use correct Manual Handling Techniques
Manual Handling whilst loading and unloading stock	Operating Staff	Back injuries	Likely	Moderate	Training of employees in correct Manual Handling practices.
Contact with Fan Blades	Operating Staff Installation Technician	Bruising to fingers Cuts to fingers	Likely	Moderate	Electrically isolate cabinet before commencing work. Use caution when accessing area for cleaning
Water leaks from Cabinet Drains	Operating Staff Service Technician Customers	Slips and Falls	Unlikely	Low	Isolate area and call service technician to repair Promptly
Water spillage onto floor from loading, unloading stock	Operating Staff Customers	Slips and Falls	Likely	Moderate	Immediately wipe up any spilled water