

FROZEN FOOD

KG16

SEMI VERTICAL GLASS DOOR FREEZER



ENHANCED ENERGY EFFICIENCY
& VERSATILITY

HUSSMANN®

PRODUCT BENEFITS

- Ergonomic design for easy access
- Alternative shelving layouts to optimise merchandising
- Optimised display with LED lighting
- Energy efficient door solution
- Low Total Energy Consumption (TEC)
- Longer merchandise shelf life
- Product temperature compliance
- Simple to install and maintain

STANDARD FEATURES

- Internal and external powder coating
- Standard door with anti fog film
- Vertical 4000K mullion LED lights
- 4 rows of 550mm solid powder coated unlit shelves
- Ticket strips
- Adjustable wire base rack with product stop
- Wire air return grill
- Rubber bumper
- Galvanised base
- Evaporator assembly fitted with valve
- Evaporator copper coil
- EC fan motors
- Digital thermometer display fitted
- Alarm probe fitted with conduit and draw wire

CUSTOMISATIONS

Shelving & Base

- Optional additional shelves and brackets
- Wire shelf and wire basket
- Product dividers
- Base basket dividers
- Wire shelf fences 75mm

Lighting

- Premium lighting available

Ends

- Solid end with powder coated trim
- Acrylic full height system divider

Bumper

- Stainless steel bumper (single or double rail)

Other

- Anti fog film applied to door
- Rear dress panel
- Technology solutions
- Electronic shelf labels or video rail

Energy & Sustainability

- Anti sweat icons

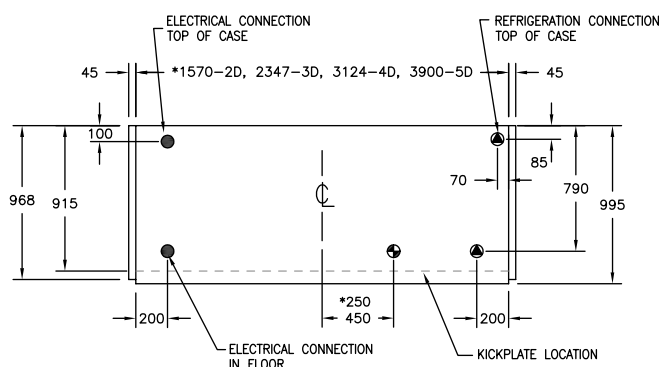
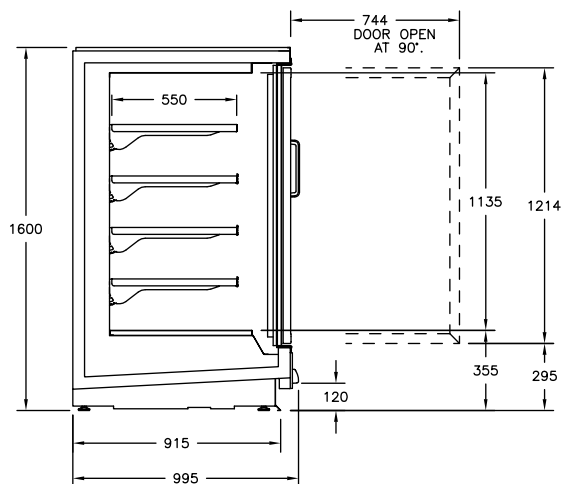

AVAILABLE LENGTHS

Excluding Ends: 1570, 2347, 3124, 3900

TEMPERATURE CLASS

3L1



(-18°C to -15°C)

AVAILABLE DEPTH

KG16 - Standard: 995

AVAILABLE COLOURS



Additional Information

All Dimensions shown in Millimetres (mm) unless otherwise stated. Dimensions and features are subject to change. Please obtain current technical information prior to order confirmation.

NOTE: We reserve the right to change or revise specifications and product design in connection with any feature of our products. Such changes do not entitle the buyer to corresponding changes, improvements, additions or replacements for equipment previously sold or Shipped.



© 2020 Hussmann Corporation - Version - V.1.0

Australia Head Office

66 Glendenning Road Glendenning, NSW 2761 Australia

ph. +612 8805 0400

w. www.hussmann.com.au

HUSSMANN®